

## B3BM Series (115 Volt)

### Air Handler

**10 and 12 SEER Residential System  
18,000 - 48,000 Btuh  
(Heat Pump & Air Conditioner)**

The B3BM Series of air handlers, when combined with our heat pump or air conditioner, offers a full line of quality, split system heating and cooling equipment.

### FEATURES and BENEFITS

- **Durable, Attractive Cabinet**—Designed using galvanized steel with a polyurethane finish. The 950 hour salt spray finish is 1.5 mil thick and resists corrosion 50% better than comparable units. The plastic drain pan is corrosion resistant.
- **Multi-poised**—Can be used in horizontal, upflow, downflow and vertical applications.
- **Multi-speed**— Gives flexibility of installation.
- **Ease-of-Service** — Plug-in wire connections and built-in filter rack makes the air handler easy to service.
- **No Fasteners on sides or back** — Smooth surfaces for installations.
- **8 Year Limited All Parts Warranty** — The best in the industry and has proven to be a major benefit to the consumer.

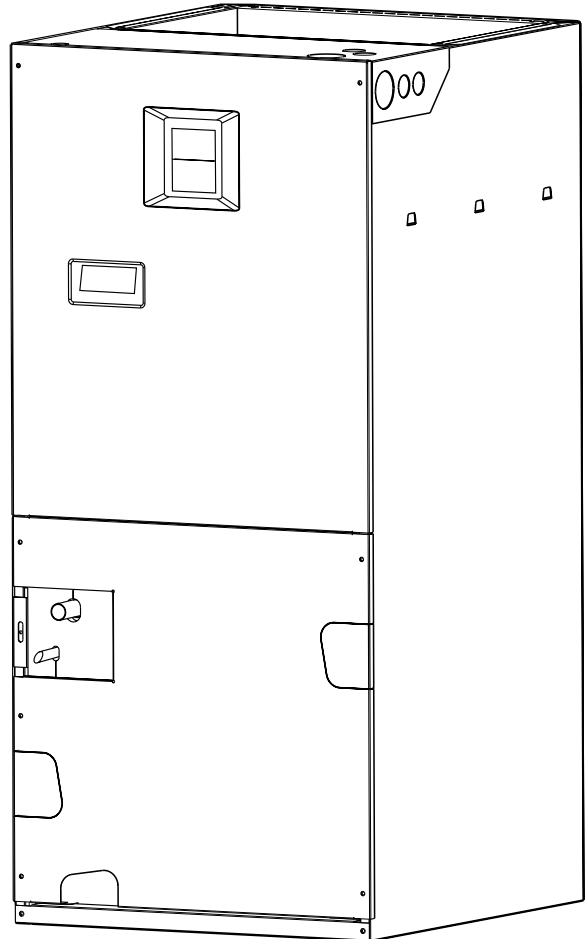

### MODEL IDENTIFICATION CODE

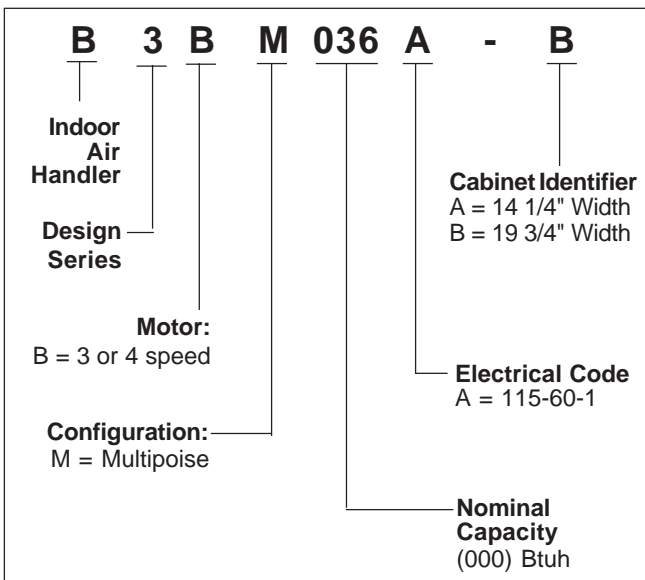

### SPECIFICATIONS

Model B3BM (115 Volt)	024A-A	036A-A	048A-B
Nominal Cooling Capacity - Btuh (1)	22,800	36,000	45,500
Refrigerant Flow Control (2)	.060 (.051)*	.067 (.063)*	.080 (.075)*
Nominal Blower Size (D x W)	10 x 6	10 x 6	10 x 8
(H.P. - Speed - Type)	1/5-3-PSC	1/3-3-PSC	1/2-3-PSC
Rated External Static Pressure (in. W.C.)	.30	.35	.40
CFM @ Rated ESP	880	1150	1450
Filter Size (see note below)	12 x 20 x 1	12 x 20 x 1	18 x 20 x 1
Approximate Shipping Weight (lbs.)	75	85	140

(1) See current ARI Directory for certified combinations and ratings.

(2) Units are 10 SEER air conditioner ready as shipped.

\* Additional orifice shipped with unit

# SYSTEM AIR FLOW DATA

Unit	HP/ Wheel	Speed	ESP ("H2O)	CFM Low	CFM Med	CFM High
024A	1/3 HP 10 X 6	3	0.1	850	1070	1210
			0.2	840	1060	1190
			0.3	790	1010	1140
			0.4	750	960	1080
			0.5	700	900	1020
036A	1/3 HP 10 X 6	3	0.1	850	1080	1220
			0.2	840	1070	1210
			0.3	790	1030	1160
			0.4	750	980	1100
			0.5	700	920	1040
048B	1/2 HP 10 X 8	3	0.1	1510	1620	1690
			0.2	1470	1580	1650
			0.3	1390	1490	1510
			0.4	1320	1410	1450
			0.5	1250	1340	1380

# DIMENSIONS

Models B3BM	H	W	A	Refrigerant Connections	
				Suction Dia.	Liquid Dia.
024-A	42	14 1/4	12 3/4	3/4	3/8
036-A	42	14 1/4	12 3/4	3/4	3/8
048-B	43 1/2	19 3/4	18 1/4	3/4	3/8

Models B3BM	Supply Air Duct Dimensions
024-A	12 7/8 x 12 3/4
036-A	12 7/8 x 12 3/4
048-B	12 7/8 x 18 1/4

# ACCESSORIES

Accessory Kit Description	Cabinet Size		Order Number
	A	B	
Downflow	X		917342
Adaptor Kit		X	917343A
No Heater Kit Available for 115 Volt			

### Notes:

- 1) Airflow is shown in cfm, +/- 5%.
- 2) External static pressure is shown in inches w.c.
- 3) All airflows are measured without filter and with dry coil. For filter velocity of 300 ft./min. subtract .08" external static pressure. For wet coil, subtract .1" external static pressure.
- 4) See unit nameplate or installation instructions for maximum recommended external static pressure.

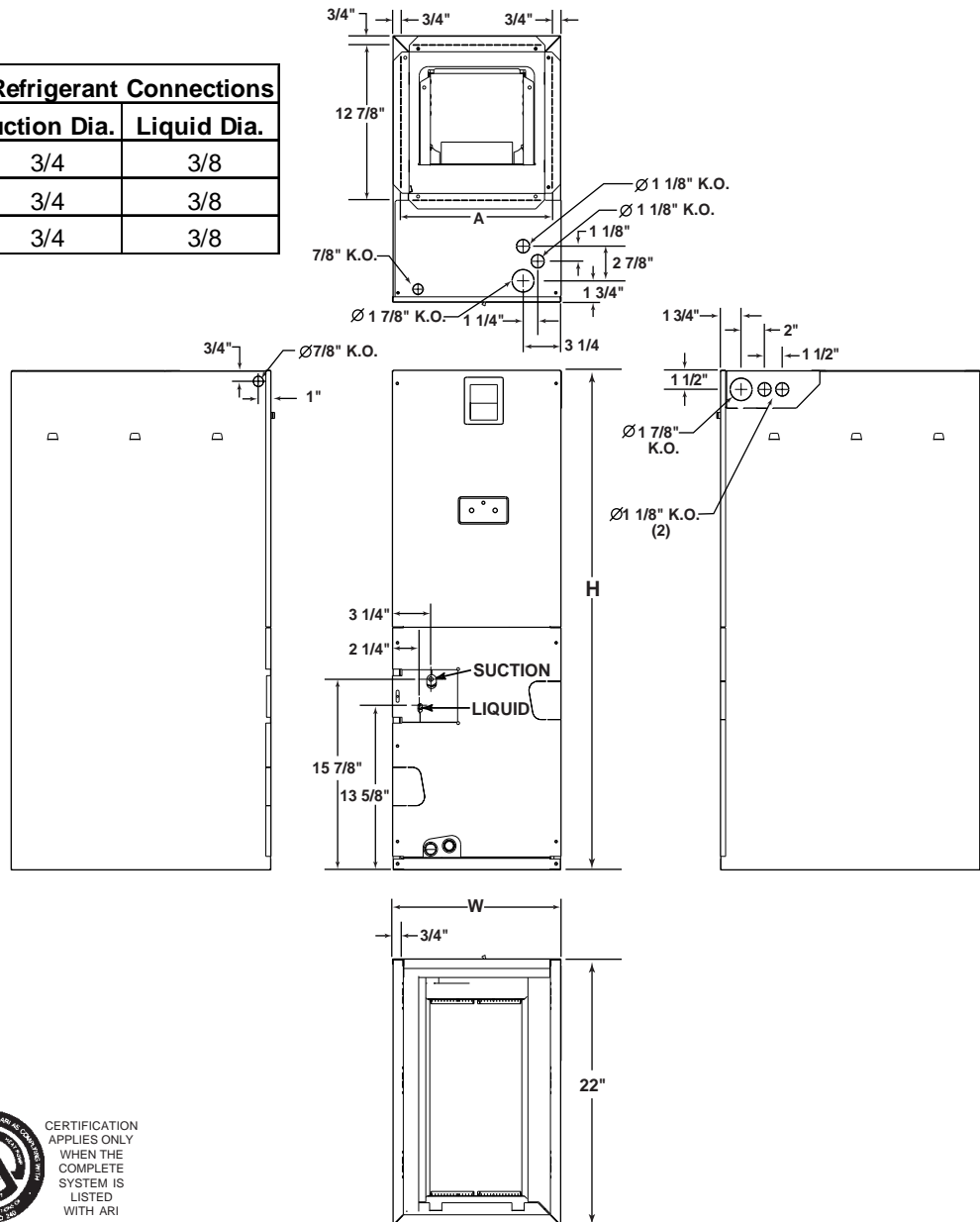

CERTIFICATION APPLIES ONLY WHEN THE COMPLETE SYSTEM IS LISTED WITH ARI

046B-0203 (Replaces 046B-1001)