

Better Duct Systems for Home Heating and Cooling

JANUARY 2001

Prepared for:
Office of Building Technologies
State and Community Programs
U.S. Department of Energy
Washington, DC 20585

Under Contract No. DE-AC02-98CH10886

**Better Duct Systems
for
Home Heating and Cooling**

JANUARY 2001

John Andrews, Ph.D., P.E.

**Prepared for:
Office of Building Technologies
State and Community Programs
U.S. Department of Energy
Washington, DC 20585**

Under Contract No. DE-AC02-98CH10886

DISCLAIMER

This report was prepared as an account of work sponsored by an agency of the United States Government. Neither the United States Government nor any agency thereof, nor any of their employees, nor any of their contractors, subcontractors, or their employees makes any warranty, express or implied, or assumes any legal liability or responsibility for the accuracy, completeness, or usefulness of any information, apparatus, product or process disclosed, or represents that its use would not infringe privately owned rights. Reference herein to any specific commercial product, process, or service by trade name, trademark manufacturer, or otherwise, does not necessarily constitute or imply its endorsement, recommendation, or favoring by the United States Government or any agency thereof. The views and opinions of authors expressed herein do not necessarily state or reflect those of the United States Government or any agency, contractor, or subcontractor thereof.

SUMMARY

This is a series of six guides intended to provide a working knowledge of residential heating and cooling duct systems, an understanding of the major issues concerning efficiency, comfort, health, and safety, and practical tips on installation and repair of duct systems. These guides are intended for use by contractors, system designers, advanced technicians, and other HVAC professionals. The first two guides are also intended to be accessible to the general reader.

The following table lists the titles, subject matter, and intended audience of the six volumes. It is expected that in final form these will be distributed as individual booklets, but they are bound together here in one report to facilitate evaluation and review.

Volume Title	Topic	Main Audiences
1. Duct Basics	How ducts lose energy Introduction to remaining topics	All audiences: Contractors, Technicians, Builders, Homeowners
2. Health, Safety, and Comfort Issues in Residential Ducts	Toxic gases and vapors Molds and mildews Inadequate cooling performance	All audiences: Contractors, Technicians, Builders, Homeowners
3. Customer Benefits from Better Duct Systems	Situations where duct repair is a big win-win for the contractor and the customer	Contractors, Builders
4. Duct Design Strategies	Recommended design options: 1. Ducts in conditioned space 2. Leak-free, insulated ducts	Designers responsible for laying out a duct system for a contractor or builder
5. Testing and Diagnosing Duct Systems	Testing for duct leakage Finding distribution efficiency	Technicians, Contractors, Builders
6. Installation and Repair of Duct Systems	Sealing and insulating ducts Correcting pressure imbalances Installing new duct systems	Technicians, Contractors, Builders

ACKNOWLEDGMENTS

This manual has received helpful comments from many knowledgeable individuals. Chief among these has been Hank Rutkowski, who provided an extensive review of an early version. Nevertheless, responsibility for the choices of what to include in the manual and for any errors it may contain lies with the author. Most of all, thanks are due to Esher Kweller of the U.S. Department of Energy, whose devotion to improved thermal distribution—spanning more than a decade—has made possible much of the technical progress that has taken place during this time.

DUCT BASICS

Volume 1

**Better Duct Systems
for
Home Heating and Cooling**

Revision Date: January 12, 2001

DUCT BASICS

This is the first in a series of guides intended to provide a working knowledge of residential heating and cooling duct systems, an understanding of the major issues concerning efficiency, comfort, health, and safety, and practical tips on installation and repair of duct systems. These guides are intended for use by contractors, system designers, advanced technicians, and other Heating Ventilating and Air-Conditioning (HVAC) professionals. The first two guides are recommended for anyone, including homeowners, who wants a deeper understanding of DUCT BASICS or HEALTH AND SAFETY TOPICS RELATED TO RESIDENTIAL DUCTS.

The duct system, used in forced-air space-conditioning systems, is a collection of channels, rectangular, round or irregular shaped tubes that distributes the heated or cooled air to the various rooms. This system can make a big difference in both the cost and the effectiveness of heating and cooling the home. The duct system can have an important effect on health of the occupants through the unintended distribution of indoor air pollution.

This guide explains the operation of a duct system and the impacts of air leakage from ducts. This and succeeding volumes will focus on how you can help your customers:

- Save money
- Improve comfort
- Protect health and safety
- Improve envelope durability

COMPONENTS OF THE DUCT SYSTEM

A duct system is a branching network of round or rectangular tubes - generally constructed of sheet metal, fiberglass board, or a flexible plastic-and-wire composite - located within the walls, floors, and ceilings. Usually, you can see only the outlet, which is a register covered with grillwork. Figure 1 shows a common type of duct system.

This system consists of supply ducts and return ducts. Central heating or cooling equipment (furnace, air conditioner, or heat pump) contains a fan that forces heated or cooled air into supply ducts leading to the rooms. The fan gets its air supply through return ducts, which in the best systems are sized properly and installed in every room of the house. To save on installation costs, most homes have one or two return registers located in common areas such as hallways. (Some homes have no return duct systems. Such design shortcuts often result in lower efficiency and higher heating and cooling bills.)

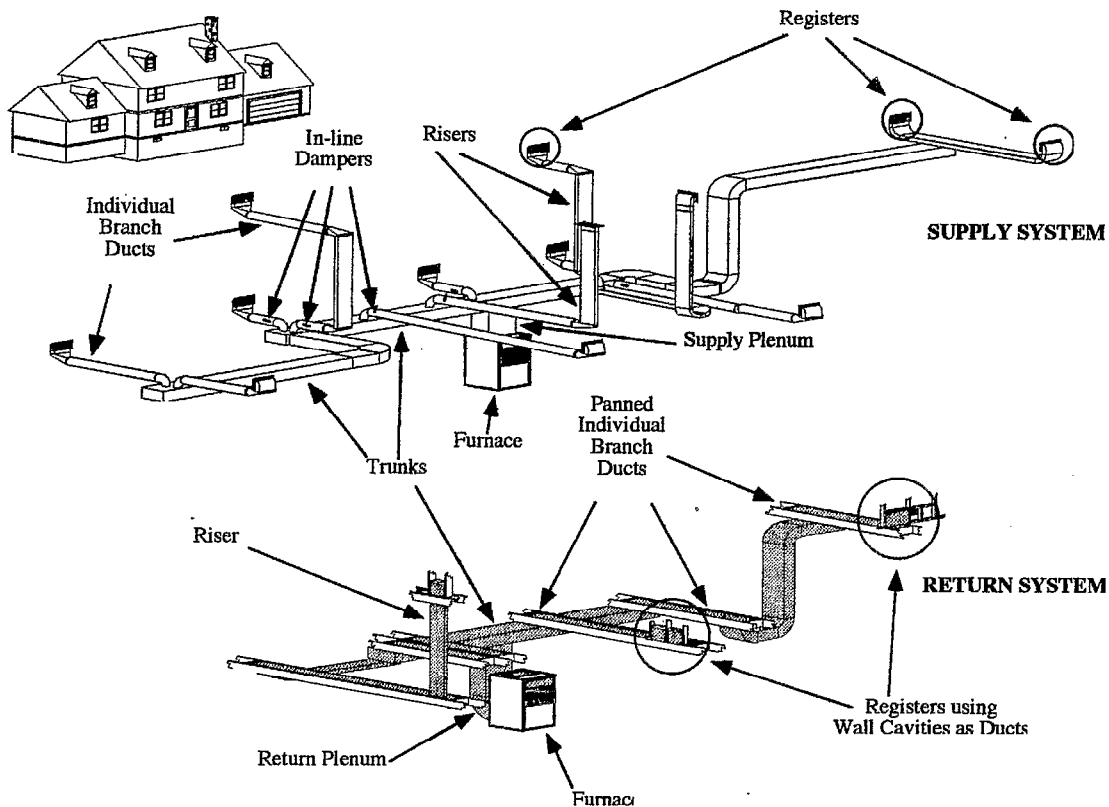

Figure 1. Common Duct System

Credit: Synertech Inc. Syracuse, New York

ENERGY LOSSES AND COSTS

Typical duct systems lose 25 to 40 percent of the heating or cooling energy put out by the central furnace, heat pump, or air conditioner. Homes with ducts in a protected area such as a basement may lose somewhat less than this, while some other types of systems (such as attic ducts in hot, humid climates) often lose more.

Duct repairs could be the most important energy improvement measure you can do if the ducts are in the attic. If only one half the typical loss of uninsulated and unsealed ducts that are in attics or crawl spaces were saved, it would amount to \$160 off the total heating and cooling bill in a typical home. This savings is based on the national average use of natural gas and electricity for central heating and cooling at national average energy cost of 70 cents per therm (natural gas), and 8 cents per kilowatt-hour (electric). With these savings, the cost to seal and insulate the ducts would most likely be paid for after three years. These estimates apply to sealing and insulating ducts in an existing home. For new construction more of the ductwork would be

accessible to the installer and the potential savings would be greater; and with lower cost to install sealant and insulate, the payback would be less than one year.

Duct systems lose energy in two ways: by conduction of heat through the duct walls, and air leakage through small cracks and seams. For simplicity, we'll talk about warm air for heating, but the same information applies to cooling when the air conditioner is on.

Conduction

One way duct systems lose energy is that the warm air inside the ducts heats the duct walls, which in turn heat the cold air outside the ducts. If the ducts are in an attic or vented crawl space that is nearly as cold as the outdoors, this heat is completely lost. If the ducts are in a basement, some of the heat lost from the ducts may be recaptured by warming the basement ceiling enough to reduce the heat lost from the house. During the cooling season, the heat flow is in the other direction, from the warm spaces outside the ducts to the cold air within them. But in either case, the result is precisely the one we don't want.

Conductive heat losses (and unwanted heat gains in air conditioning) are typically responsible for about half the energy inefficiency in duct systems. Conduction is an easy-to-understand process. It is encouraged by large temperature differences between the inside and the outside of the duct and by large areas of ductwork exposed to these temperature differences. It is inhibited by insulation. For this reason we won't have much more to say about it. The reason we give a lot more space to duct leakage is not that it is more damaging to efficiency, but because it is more subtle and complicated, and also because air leakage causes most of the health and safety concerns that arise in duct systems

Air Leakage

Another way that ducts lose energy is through air leakage. Sometimes this leakage is from accidental holes in the ducts or poorly connected duct sections; but even if the ducts are sealed, their operation can cause the house itself to leak more air than would otherwise be the case.

An understanding of pressure differences in the duct system helps to better understand air leakage in the home. Air moves from high pressure to low pressure. To get air to move from the supply duct into the room it serves, the air in the duct has to be at a higher pressure than the air in the room. Similarly, to move air from the room into the return duct, the air in that duct has to be at a lower pressure than the air in the room. The registers are the openings through which this air is intended to move. The duct walls provide the barriers that prevent air from moving where we don't want it to go.

The fan of the central furnace creates these pressure differences. When the fan stops, these pressures quickly equalize and the flow of air through the duct stops, too.

Figure 2 shows a duct system that does not leak. The furnace fan produces a high pressure in the supply ducts and a low pressure in the return ducts. The high pressure forces warm air from the supply ducts to flow into the rooms, and low pressure draws room air back into the return ducts.

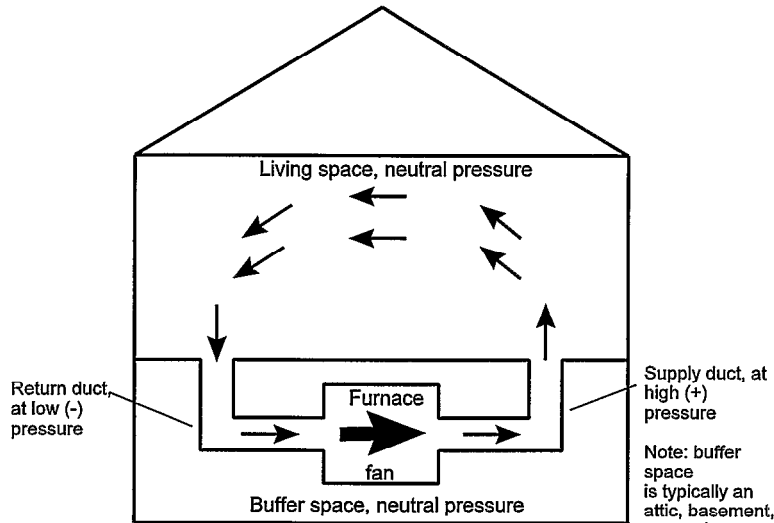

Figure 2. Ideal Duct Schematic - No Leakage

- **Leaky Supply Ducts**

Figure 3 shows perhaps the simplest example of duct leakage. Here the supply ducts leak, but the return ducts are air tight. Even though half the duct system is good, two bad things still happen. First, some of the air that has just been warmed by the furnace is lost. Second, this air has to be replaced. If it weren't, the house would soon be pumped down to a vacuum, and we know that doesn't happen. What does happen is that cold air from the outside is drawn into the

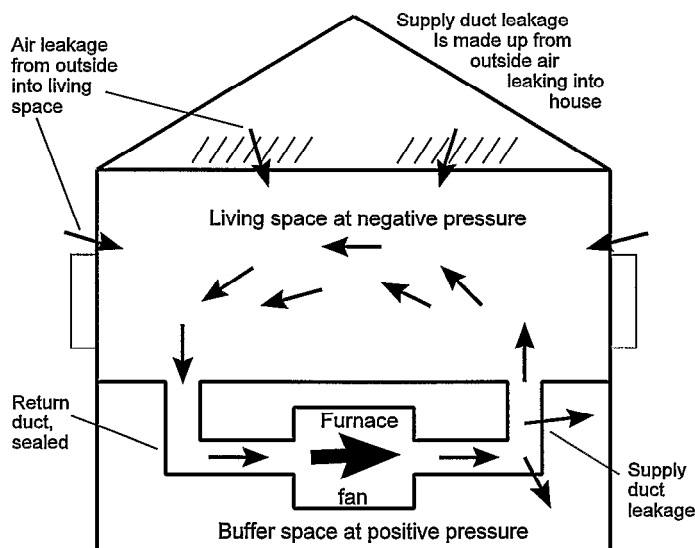

Figure 3. Duct System With Supply Side Leaks

house through cracks and small holes in the outside walls. Usually these occur around doors and windows. Some houses have more of these than others, but no house is air tight. So we've lost some of the hottest air in the house (air that just came from the furnace), and replaced it with the coldest air around (air from the outside). In other words, a leaking supply duct is an energy loser in two ways: the energy loss that does not go to the rooms, and the extra energy needed to heat cold air that leaked into the house.

- **Leaky Return Ducts**

Suppose the supply ducts are tight but the returns leak, as shown in Figure 4. The return duct is at a low pressure—lower than the house or the outside—so cold air from the outside is pulled into this duct. This cold air is heated in the furnace (along with air that came from the house through the return registers). The amount of air delivered to the house by the supply registers is greater than what the return ducts took from the house (the difference being the cold air that leaked into the return ducts). To equalize the flows, heated room air leaks out of the house through the same holes and cracks that, in the previous example, allowed air to leak in. So cold air is pulled in and warm air leaks out. In addition to creating energy losses, leaky return ducts can create health problems (see below).

During the cooling season in hot, humid climates, leaky return ducts can be even more of a problem, because they can upset the balance between the need for reducing the indoor temperature and the need for reducing the humidity. If the ducts are in a relatively cool but humid space, such as a vented crawl space, the air leakage into these ducts will add a lot of moisture to the air in the house but will not increase its temperature very much. So the air conditioner will satisfy the thermostat nearly as quickly as in the absence of such leakage, but it will leave the house in an excessively damp condition.

It should also be noted that joints and penetrations in the air-handler cabinet and any add-on filter installations are often major contributors to the return-side duct leakage. Since these are the

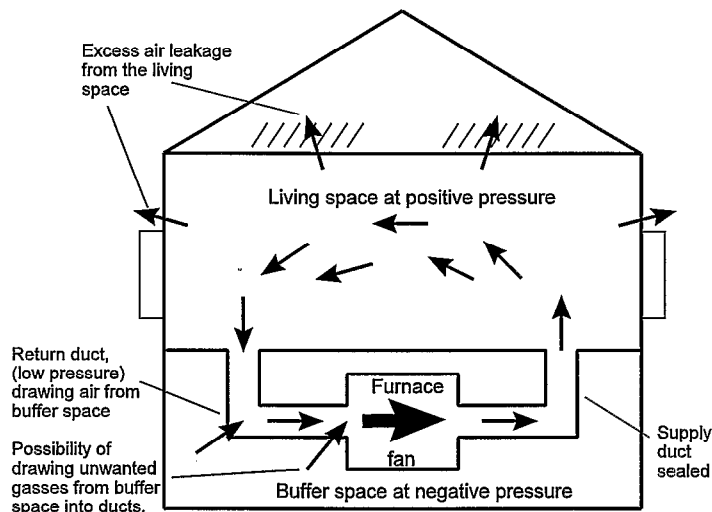

Figure 4. Duct System With Return Side leaks

locations of greatest negative pressure anywhere in the system, even small holes can give rise to significant amounts of leakage.

- **Zone Pressurization**

Ducts can cause air leakage in the house even if neither the supply nor the return ducts leak themselves. Figure 5 shows how this can happen. Imagine that a home has a return register in one room but no supply (the room on the left in Figure 5), and a supply register in another room but no return. Now close the door between these rooms. The room with the supply duct (the room on the right in Figure 5) will have relatively high pressure. The supply duct will be trying to blow this room up like a balloon. Similarly, the room with the return will have relatively low pressure. So inside air will leak out from the room on the right, and outside air will leak into the room on the left. This places an added load on the heating equipment. The situation described here is somewhat simplified to show the basic idea, but variations of it are common in real homes. Most new homes built today do not have duct returns in each room. The problem can be avoided in rooms with no return register and doors that are often closed by installing an opening covered by a louvered grill in the door or in the adjoining wall. This grille may need to be larger than one would think. Volume 5 of this series gives a suggestion on how to size grilles.

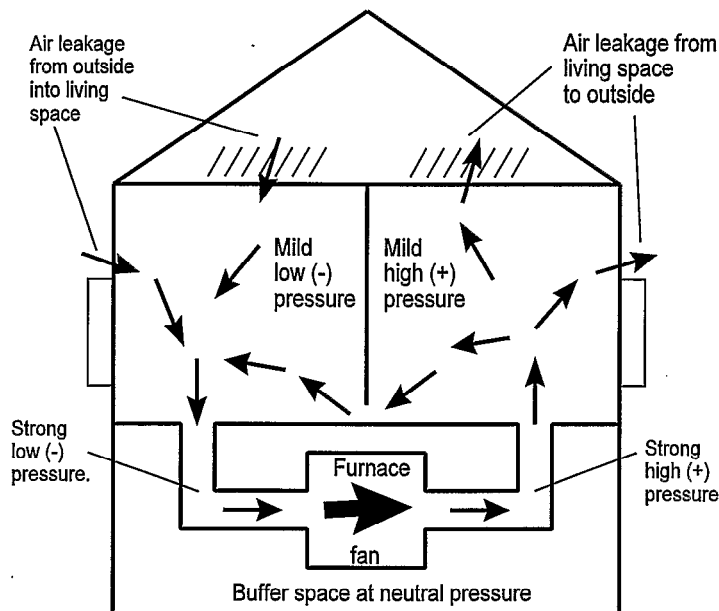

Figure 5. Excess Air leakage In The House Caused By Isolation Of Zones

- **Energy Losses When the Fan Is Off**

So far, we've been talking about what happens when the central furnace fan is running. But even when it's off (which is most of the time) the leaks in ductwork add to the air leaks in the rest of the house. The cracks in ductwork typically have an area that is 10 to 20 percent of the leakage

area of the house. Over the course of a heating season, the energy losses from ducts when the fan is off can be nearly as great as when the fan is on!

DUCTS ARE PART OF A SYSTEM

Ducts have an important job to do, but they don't do it alone. They need equipment to provide them with the heated or chilled air to distribute throughout the building, and the spaces to which they deliver this air must be surrounded by a building envelope. That much is obvious, but interactions between ductwork and the rest of the building can often produce some surprising effects. So it is important to consider them at the beginning.

Duct energy losses and equipment inefficiencies can work together to give surprisingly low overall system efficiency. When a furnace meeting the current national standards (78% Annual Fuel Utilization Efficiency) is combined with a typical duct system installed in a vented attic or open crawlspace (60% - 75% seasonal efficiency), only about half the heating value of the fuel will make it into the house! Heat pumps and air conditioners are "in the same boat" as furnaces, although the calculation is somewhat more involved. Two or more energy losses, each of which might seem "not too bad" in itself, can add up to a very disappointing result. Ducts are too often "out of sight, out of mind."

Ducts interact with the rest of the building primarily in the following ways:

- **Thermal Regain (Recovery of Lost Energy)**

Most residential forced-air distribution systems in the U.S. have their ducts in an attic or crawl space that is not conditioned but which is adjacent to the conditioned space. (Basements containing ducts are sometimes intentionally conditioned, sometimes not.) If this "buffer zone" is not vented (true of most basements and some crawlspaces) any heat lost from these ducts may warm the zone significantly. This rise in temperature, compared with what would happen if there were no ducts, retards heat loss from the conditioned space into the buffer zone containing the ducts. It also retards heat conduction through the walls of the ducts themselves (although it does not, of course, retard air leakage). These benefits can soften the energy penalty of the losses, that is, it is the same as if some of the lost heat is recovered. Figure 6 illustrates the concept. This effective recovery of lost energy, called thermal regain, can also occur in cooling.

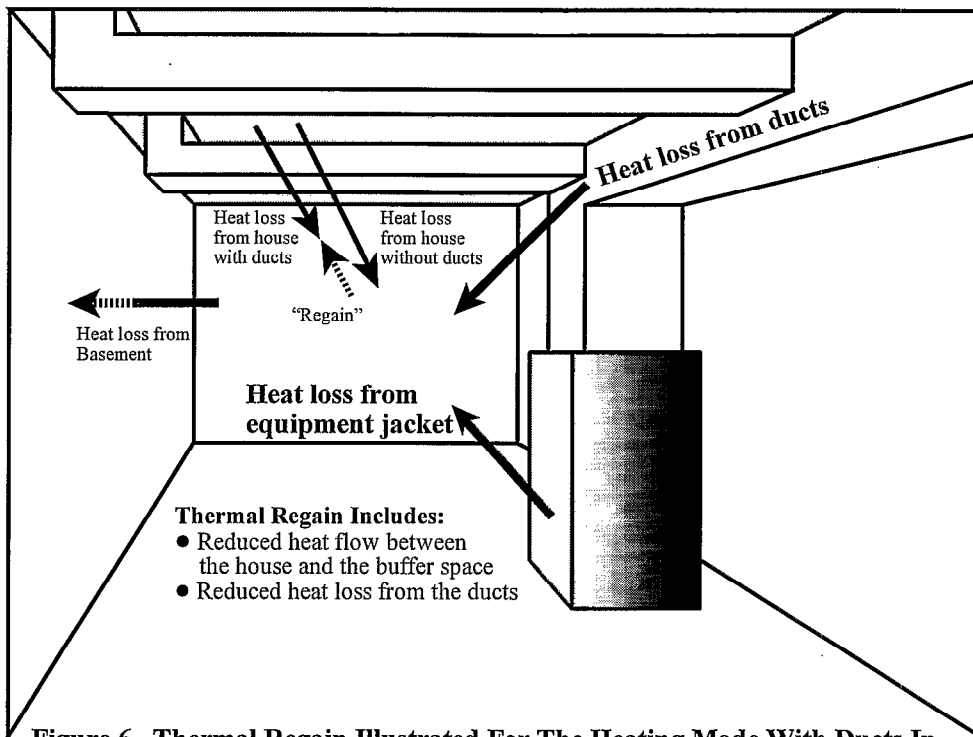

Figure 6. Thermal Regain Illustrated For The Heating Mode With Ducts In An Un-insulated Basement.

- **Equipment efficiency**

Energy losses from ducts generally result in a greater load on heating or cooling equipment than would be the case with a perfect duct system, even after any thermal regain has been accounted for. This increased load can raise or lower the efficiency of the heating and cooling equipment. With single-capacity furnaces and single-speed air conditioners, the impact of ducts on equipment efficiency is usually too small to notice. With variable-capacity equipment (this includes heat pumps with resistance backup coils) an inefficient duct system can seriously degrade the equipment's average efficiency over an entire season.

- **Pressure effects**

Some of these have already been discussed. Operation of the central air-handler fan usually causes the distribution of pressures in the house to change. These pressure changes may affect the rate at which outdoor air infiltrates into the home, generally increasing (though sometimes decreasing) the heating or cooling load. They may also affect the health and safety of the building occupants.

Duct Location and Thermal Regain

Thermal regain underpins any discussion of where ducts should be located within the home. The higher the thermal regain factor, the better the location.

The best places for ducts are in spaces that are intentionally heated, or that retain lost heat exceptionally well. If ducts are located within the conditioned space, then any lost heat or cooling is not really lost (although it may be necessary to rebalance the system to attain proper distribution within the home). If a basement is intentionally conditioned (generally speaking, if it has registers and is used for family activities) then it should be considered part of the conditioned space, with 100% regain. If the basement walls are insulated, regain will approximate 75% even if the basement is not intentionally conditioned. Another good place for ducts, at least from a thermal standpoint, is under a slab (but not right at the edges of the slab if it isn't insulated). But because in-slab ducts are "set in concrete," they are probably not a good choice for any but the most knowledgeable and experienced builders.

Ducts in unvented, uninsulated basements and crawl spaces and exterior walls regain about half the heating or cooling value of the thermal losses. While that is better than nothing, they are not the best choices for new construction. There is some evidence, moreover, that ducts in basements may, as actually installed, leak more than those in crawlspaces and attics, possibly due to a belief that thermal losses from such ducts don't matter. Fifty percent regain doesn't help much if the losses are twice as great. As for exterior walls, modern practice is moving toward the use of interior walls, where the regain is 100%, but for existing homes where the ducts cannot be moved, the 50% regain factor is a good average number, though individual cases may vary significantly.

All other duct locations have regain factors ranging from 30% down to essentially zero, and should be avoided if possible. Basements and crawlspaces under an insulated floor, attics, and garages are common examples of these locations. It should be noted that even though basement ceiling insulation lowers the regain factor, the heat-loss reduction benefit from the insulation almost always exceeds the effect of the reduced regain factor. It should also be recognized that going from a totally uninsulated basement (including supply ducts) to one in which the basement ceiling and the supply ducts are insulated will usually cause the wintertime average basement temperature to drop, often by more than 10 °F. When ducts are located in a basement, insulating the basement walls rather than the ceiling is recommended because it increases the regain factor and makes the basement warmer in winter.

These discussions are summarized in Figure 7, which shows the relative merits of various duct locations in terms of the degree to which lost heat or cooling may be regained.

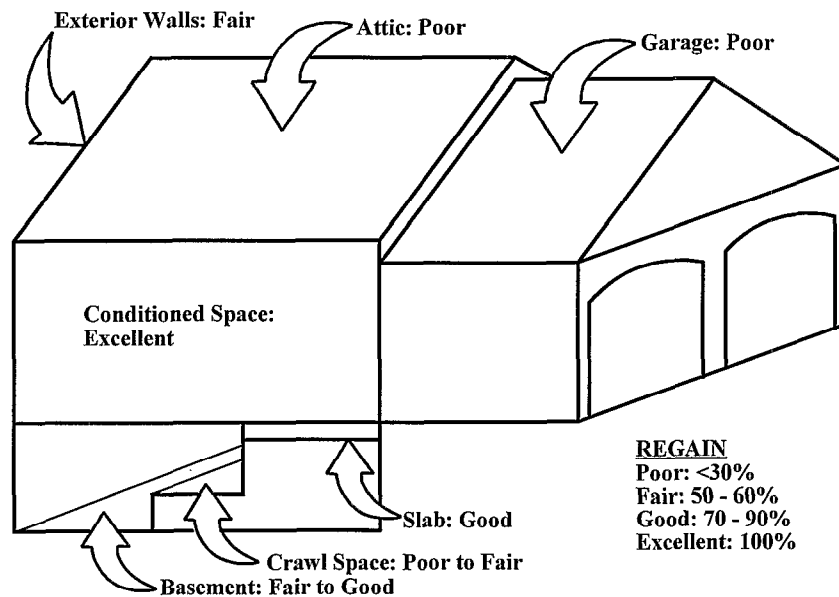

Figure 7. Relative Merit Of Various Spaces In Which Ducts May Be Located, In Terms Of Their Thermal Regain Potential.

Thermosyphoning

To the extent that thermal regain occurs, duct energy losses are reduced. Another effect that depends on duct location can make duct losses worse. This is thermosyphoning.

Thermosyphoning usually occurs when the duct system is spread out over more than one level. For example, some ducts might be in the attic (with ceiling registers) with the rest in the crawl space (connected to floor registers). Consider what can happen during the heating season. When the fan shuts down, the ducts are full of warm air. As the air in the ducts loses heat to the outside and gets cold, it sinks to the lowest level in the system and enters the house through the floor registers. To replace this cold air, warm air from the rooms is pulled into the duct system through the ceiling registers, where it then also cools down, continuing the thermosyphon loop.

Thermosyphon loops effectively transfer heat from the house to the outside, the opposite of what we want. The flow direction in such loops is also usually in the opposite direction to the normal flow. In new construction, these loops can be avoided by placing the ducts in the conditioned space, or at least avoiding split-level duct configurations. In existing systems, the effect can be mitigated by adding insulation to ducts that are outside the conditioned space.

More on Interactions Between the Ducts and the Equipment

The efficiency of a duct system can affect the efficiency of the equipment. The vast majority of homes today are heated with furnaces (gas, oil, or electric) and cooled with an air conditioner employing a single-speed compressor. For such systems, the impact of duct efficiency on equipment efficiency can usually be ignored. The purist will note that a furnace may expect to lose a percentage point or so in efficiency when the ducts are improved by 20% (this is because the furnace will cycle more often under the reduced heating load) but any such effect will be "lost in the noise."

Far more important with this most common type of system is that insulating ducts and repairing leaks makes it possible to downsize the equipment. Whether selecting the equipment in new construction, or deciding to do duct repair when equipment needs replacing, the ability to use a smaller heating/cooling plant saves on the up-front cost (particularly in cooling) and in new construction allows the ducts themselves to be downsized. This results in an excellent and exemplary design process, "a virtuous circle," with one improvement leading to the possibility of another.

Heat pumps are a special case. The most common type of air-source heat pump employs electric resistance backup heaters, which come into play as a falling temperature increases the heating load and decreases the ability of the compressor to meet that load. These resistance coils are much less efficient than the heat pump itself. Therefore, any change to the rest of the system that reduces the heat pump's dependence on resistance backup is sure to improve the overall efficiency of the machine. Sealing and insulating ducts reduces the load that the heat pump must meet at any given outdoor temperature. As a result, the compressor can handle the load down to lower outdoor temperatures than before. This can result in an overall improvement in system efficiency that is 50% greater than what one would expect from considering the ducts by themselves. Insulating supply ducts also raises the delivered air temperature in the heating mode, a significant comfort benefit in heat pump systems because of reduced perception of draftiness. For these reasons, duct efficiency is even more important in heat pump systems than it is in systems using furnaces.

Variable-capacity furnaces and air conditioners are the "new kids on the block." Like heat pumps, they have two operating modes, one of which (the low-capacity mode) is usually more efficient than its higher-capacity counterpart. For the same reasons as those discussed above, improvements in duct efficiency will give an added benefit in average equipment efficiency.

It's important to emphasize that the above discussion refers to the efficiency of the *equipment*, not the ducts. That is, the benefits described in this section are *in addition* to the benefits from reduced duct losses.

Geothermal heat pumps are rapidly increasing in popularity. Key to their success is minimizing the cost of the in-ground heat exchanger. It's counterproductive to incur the cost of extra

borehole just to feed duct losses. An optimized geothermal heat pump system will almost always have its ducts in the conditioned space.

More on Air Infiltration Impact

We now know that ducts are part of a much larger system and that they can significantly impact the overall energy performance of the entire house. Equipped with this knowledge we will review and expand on the discussion of air infiltration effects and zone pressurization which impact the whole house as a system.

Operation of the air handler fan often changes the distribution of air pressures within the house. These effects are quite small when compared with the total pressure of the atmosphere, or even when compared with the much smaller pressure changes associated with changes in the weather. Nevertheless, they may significantly increase the amount of unconditioned air that is drawn into the house (air infiltration).

Operation of the system fan can change the air infiltration rate in two different ways. The first occurs if the air leakage rate from the supply ducts to the outside is different from the leakage rate from the outside into the return ducts. Suppose, for example, that the supply leakage rate is greater than the return leakage. In this case, the duct system as a whole loses a net amount of air to the outside. Since the ducts can't keep on losing air very long, they make it up from the house itself, by pulling a little more air into the return registers than they deliver at the supply registers. This pulls a slight suction on the house, which in turn causes more outside air to infiltrate through cracks in the envelope than would otherwise be the case. In the reverse case, where the return ducts leak more than the supply ducts, the system fan actually raises the pressure in the house and this in turn will cause the infiltration rate to drop. Usually, this reduced infiltration is more than offset by the fact that the ducts are sucking in a net amount of outside air that must be heated or cooled.

System fan operation can also affect the pressures in particular zones of the house, especially if there is only one return register and this register can be isolated from some of the rooms by closing doors. A typical case is where the return register is in a central hallway. When bedroom doors are closed, the supply ducts cause the pressure in these bedrooms to rise, forcing conditioned air out of the house. At the same time, the zone containing the return register is depressurized, which increases the infiltration of outside air into this area. This effect tends to make duct systems less efficient. Zone pressurization is important, besides increasing energy use, it can affect health, safety, and comfort in several ways.

HEALTH HAZARDS AND THERMAL COMFORT PROBLEMS

Leakage in the duct system can be hazardous to your customers' health. Especially problematic are leaky returns in an enclosed space such as a basement or garage that also contains the furnace. This was the situation shown in Figure 4. If the return ducts leak, their low pressure can pull down the pressure in the basement or garage as well, and this can suck flue gases from the furnace and radon gas from the soil surrounding the home. The flue gases can be hazardous to health if they contain carbon monoxide. Exposure to radon gas from the ground is the second leading cause of lung cancer (after smoking). Although experts disagree about how common these hazards are, by upgrading the energy efficiency of the duct system you have an opportunity to avoid these potential problems in the home.

Inefficient ducts can also give rise to thermal comfort problems. One problem seen fairly often in Southern climates is insufficient cooling capacity on the hottest days of the year. Here the first thought is usually to blame the air conditioner, but often the problem is leaky or poorly insulated ducts that add so much to the cooling load that the air conditioner can't handle it. Fix the ducts and the problem may go away. Other comfort problems that are sometimes caused by inefficient ducts include poor humidity control, poor conditioning of certain rooms in the house, and too-low delivered air temperatures in heat pump systems.

Even if comfort isn't directly affected, more subtle, long-term pressurization or depressurization conditions can cause degradation of the building envelope. In cold climates during the winter, pressurization of the interior can drive moist air into exterior walls, where condensation of moisture can lead to mold growth and deterioration of wood and other materials within the wall cavity. In hot, humid climates it is depressurization that may cause problems. In this case the moisture is outside; when this is sucked into the wall, similar problems can arise.

The second volume in this series discusses health, safety, and comfort topics in greater detail.

INSPECTING AND TESTING DUCT SYSTEMS

You probably wonder how you can know if a duct system is losing large amounts of energy. Although it is often difficult to be sure without testing, some tell-tale signs, if present in the duct system, should help you convince your customer that testing would be a good idea.

It will help to make a simple diagram of the system. This can be a rough sketch. There is no need for blueprint quality here. Start with the central heating unit, which may be in a basement, garage, crawl space, attic, or in the living space itself. Then work forward into the supply duct system and backward through the return system. If it isn't obvious which are supply and which are return ducts, follow the ducts to the registers and notice whether air is being sucked in or blown out when the system fan comes on.

There are several different kinds of system arrangement. In one common type of installation, the return duct leads down from the basement ceiling to enter the furnace near the floor. The supply duct runs out from the top of the furnace. This kind of system is shown in Figure 1. Another common installation has all the supply ducts branching directly from the furnace like the arms of an octopus. You should be able to identify every register in the house, every supply and return branch of the duct system, how they connect to major supply or return trunks (if present in the home) and the connections to the plenums at the furnace or heating unit. Nearly every house is different.

You will feel more confident, and gain your customer's confidence as well, if you know your way around the particular system on which you are proposing to work.

Safety

It is assumed that users of these guides are familiar with basic safety rules around home heating systems. The following is just a useful checklist:

- Guard against falls, cuts, and other personal injuries.
- Unless you are a trained electrician, do not open up or probe into any electrical devices, wires, or connections.
- Wear an approved mask if you go into an area with fiberglass or loose fill insulation.
- Before you touch any uninsulated duct, hold your hand about an inch from it to check if it is hot. This is especially important in furnaces fueled with gas or oil, because what looks like a small duct might actually be the vent pipe, and this might be at a temperature of several hundred °F.

Filters

While you are at it, you might want to locate the filter, which is usually within the central fan unit or at the return register. The filter removes dust and other small particles that otherwise could interfere with the operation of the blower and the furnace heat exchanger.

A detailed discussion of filter selection is beyond the scope of this manual. What can be said is that the filters supplied with HVAC equipment often do little more than protect the fan against impingement by large particles such as sand and grit. Reducing the volume of smaller particles, which are the ones that typically cause health problems, usually requires an add-on filter. Regardless of filter type, however, the homeowner should be cautioned to guard against clogging of the filter, which can drastically reduce air flow. (Even electrostatic filters have mechanical pre-filters that can and do clog if not cleaned.) Cleaning or changing the filter two or three times a year is a very worthwhile practice. If one does install an additional filter, it is important to

make sure that the filter cabinet is adequately sealed against leakage from the outside. Add-on filters installed near the return plenum—at exactly the point where the pressure that drives air leakage is usually greatest—often contribute a significant fraction of the air leakage into the return duct.

Building Spaces Used as Ducts

So far we have assumed that the duct system is completely separate from the other components of the home. Often this is not so. To save money, builders sometimes use the building structure itself as part of the duct system. One common tactic is to use the spaces between basement or ceiling joists as ducts. (Joists are the horizontal-running boards—generally 2" x 10" or 2" x 12"—that support the floor above.)

Although this type of construction can be made to operate efficiently, it often leads to significant energy losses. One reason is that joist-space ducts are likely to be uninsulated. Another problem is that they may have unintended leakage paths to the outside, typically through the end of the joist cavity.

With returns, it is even more common to see portions of the building structure used as part of the duct system. Some homes have no return at all; the furnace simply has an intake grille through which air is drawn in to be warmed and distributed to the home.

TELL-TALE SIGNS OF PROBLEM DUCTS

Now that you know where each branch duct leads, you are in a better position to ask whether a duct system is likely to be a big energy loser. Here are the things to look for.

Uninsulated Ducts in Unconditioned Spaces

Heat transfer through duct walls can contribute significantly to energy losses. Conductive heat losses are typically at least as great as the energy losses due to air leakage. If the duct system runs through an attic or vented crawlspace and is not insulated, you can be sure that much energy is being wasted. If the ducts are in a basement, you will have to weigh the fact that insulating the ducts will cause the basement to get colder. If both the ducts and the basement walls are uninsulated, you should consider insulating the basement walls instead of the ducts.

Disconnected, Torn, or Damaged Ducts

A thorough inspection of the duct system should be made to look for holes large enough to see. Some sections of duct that are supposed to be joined together may have fallen away from each other, leaving a gap through which large quantities of air can leak. Flexible duct sections may have been torn during installation or afterward. Fiberglass ductboard sections are subject to

damage if weight is placed on them. Whatever the cause, visible holes in ductwork are a clear indication that the system needs fixing.

Blind-Alley Ducts

Occasionally found in duct systems that use joist spaces or other parts of the building structure to channel air flow, blind-alley ducts occur as a result of mistakes made during installation. A blind-alley duct leads nowhere (except possibly to the outside), while the register it was supposed to serve has no source of heat. The room containing this register will then be too cold. If it is an important room, the thermostat setting may be raised in an attempt to get enough heat to this room. If a room always seem too cold or a register doesn't seem to have any air flowing out of it, it may be worth investigating.

Inadequate Return-Side Ductwork

As we've noted, it is common to find building spaces pressed into service as part of the duct system. These tend to be leaky, especially on the return side. Even worse, some homes are designed without any return ductwork at all. In that case, unless the furnace is in the conditioned space, it will be surrounded by cold basement or crawl-space air and will have to use more energy to warm this cold air for delivery to the home than it would have if warmer air from the living space were available from return ducts. A system without return ductwork can also depressurize the furnace room, giving rise to the health hazards we've already discussed.

Other Evidence of Supply- and Return-Side Leakage

In any kind of duct system, the joints between duct sections should be sealed against leakage. If duct tape was used for this purpose, it often loses adhesiveness after a few years. In such cases you can see it falling off the ducts or you can easily pull it away. If the return ducts are insulated, you may see accumulations of soot or other dark material on the insulation where it covers loose duct joints. This dark area is a coating of dust which over time has accumulated on the surface as the air is being pulled through the insulation.

Another fairly common type of energy-wasting air leakage is found in systems where ducts, water pipes, or vent pipes lead between the basement and the attic. If there are openings around these pipes that allow heated air to flow out or cold air to flow in, then the pressure difference between the basement and the attic is likely to increase air infiltration into the basement. It is usually a good idea to seal this flow path.

These are all signs that serious duct leakage may be occurring, leakage that could, with reasonable effort, be eliminated.

DUCT TESTING

Once the need for further testing of the duct system has been identified, the next step is to do the testing. Another guidebook in this series covers detailed test procedures, but it is useful to introduce some of the test equipment here for those readers who only want a brief idea of what the equipment available to the trained service technician is used for when diagnosing residential duct systems.

Digital Manometer

The digital manometer (Figure 8) is a hand-held electronic device that can measure very small pressures, to an accuracy of 0.1 pascal. One pascal is a very small pressure, equal to 1/250 of an inch of water column or 1/100,000 of atmospheric pressure. Accurately measuring small pressure differences between various points in the duct system, and in the other pieces of test equipment, is essential in duct testing.

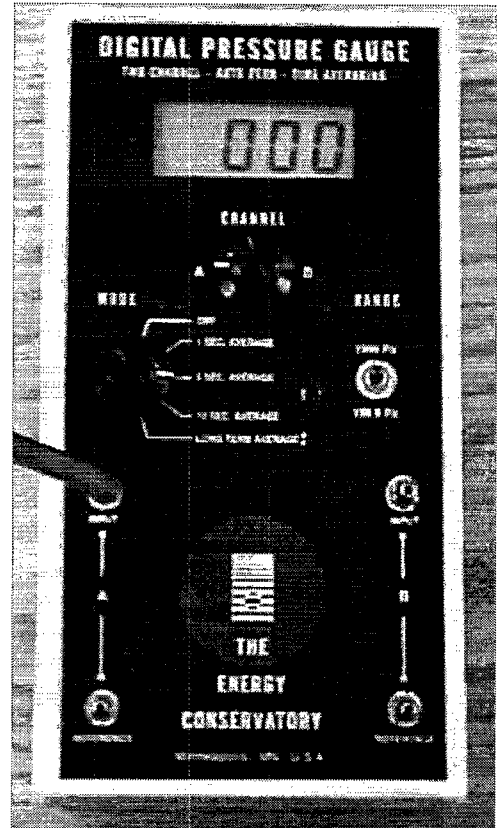

Figure 8. Digital Manometer



Figure 9 Duct Blower

Duct Blower

The duct blower (Figure 9) is a calibrated, adjustable-speed fan that is used to blow air into one opening of a duct system that has all registers and any other openings sealed over. The amount of air needed to maintain a certain pressure is a measure of how leaky the duct is.

Blower Door

The blower door (Figure 10) is a big brother of the duct blower. Set up in a temporary baffle installed in a doorway, this adjustable-speed fan is used to pressurize a whole house, not just a duct system. The main use of the blower door is to test for air leakage in the house, but it is also used in duct leakage tests. One test for duct leakage involves simultaneously pressurizing the house with the blower door and the ducts with a smaller version of this device known as a duct blower. Another test uses the blower-door result plus some simple pressure measurements to estimate duct leakage.



Figure 10 Blower Door

GOLDEN OPPORTUNITIES FOR IMPROVING DUCT SYSTEMS

In addition to looking for direct evidence of problems in an existing duct system, there are several general conditions that point toward a probable customer benefit from a duct upgrade. These include:

Possible Comfort, Health, or Safety Issues Have Been Noted

If the customer complains of rooms that are too cold or too warm, or if conditions exist that are likely to give rise to health and safety problems, the duct system should be tested for leakage. Consult volume two of this series for more information.

The Home is Heated and Cooled with a Heat Pump

Most heat pumps have electric-resistance backup coils, which come on during cold weather when heating loads are high and the ability of the heat pump's compressor to pull heat in from the

outside is at its lowest ebb. Repairing a leaky or poorly insulated duct system not only reduces the part of the heating load arising from duct losses, it reduces the amount of inefficient backup heat that the heat pump must supply. This is one of the few cases where a "double-dip" benefit is legitimate and real.

The Heating or Cooling Equipment Needs to Be Replaced

When equipment needs replacing, it is a particularly good opportunity for fixing the duct system as well. By improving the efficiency of the duct system, the peak load is reduced and it may be possible to select a smaller unit. In the case of an air conditioner, this will save on first cost and will probably improve delivered thermal comfort as well.

The Home is in a Hot, Humid Climate and the Ducts Are in the Attic

Duct systems in this category have proved to be especially poor performers. Seasonal-average efficiencies for the duct system are often less than 60%, and peak-load duct efficiency tends to be even lower. In some cases, the duct losses are so great that the system cannot keep the home cool during the peak summer heat.

These "golden opportunities" are discussed further in Volume3: CUSTOMER BENEFITS FROM BETTER DUCT SYSTEMS.

OPPORTUNITIES IN NEW HOMES

We have discussed some issues facing HVAC professionals working in existing homes. If you are a builder of new homes, you also have the opportunity to make sure that the duct system will deliver top-notch comfort and efficiency, in this case by specifying from the outset a duct system in which leakage is held to a strict maximum standard (generally 5% of the fan flow, or less, on both the supply and return sides of the system) and which is appropriately insulated.

Even better, consider the option of locating the ducts within the conditioned space and hiding them so that they don't show. It is possible to box in ductwork installed near the intersection of a wall and the ceiling, or to use other builders' tricks so that the raw duct materials will not be visible. It will be easier to do this than might at first appear because an energy-efficient duct system in an energy-efficient home can be less bulky than a standard duct system. This is because the amount of heating and air conditioning needed will be much less than in a standard installation. This will permit the use of a smaller furnace and air conditioner, which require a smaller amount of air flow in the duct system.

When it is possible to reduce the size of the duct system and the central unit, you save on equipment, materials, and installation costs, possibly enough to pay for the cost to hide ducts that

are located within the conditioned space. In that case, energy savings will start to flow immediately. Even if some additional cost is involved, a duct system properly installed inside the conditioned space is energy loss-free and will likely be one of your customer's best investments.

FOR FURTHER INFORMATION

The first two references below are readable guides requiring no specialized knowledge, although the professional can pick up quite a bit from them, too. The others are really intended for the professional almost exclusively.

Home Energy Magazine, Special Issue-Ducts Rediscovered. September/ October 1993. 2124 Kittredge Street, No. 95, Berkeley, CA 94704.

This Old House; Heating, Ventilation, and Air Conditioning. Trethewey, Richard. Little, Brown. 1994.

Duct Design for Residential Winter and Summer Air Conditioning and Equipment Selection (Manual D). Air Conditioning Contractors of America, 1513 16th Street, N.W., Washington, DC 20036.

Flexible Duct Performance and Installation Standards. Air Diffusion Council, One Illinois Center, Suite 200, 111 East Wacker Drive, Chicago, IL. 60602-5398.

A Guide to Insulated Air Duct Systems. North American Insulation Manufacturers Association, 44 Canal Center Plaza, Suite 310, Alexandria, Va 22314.

Installation Standards for Residential Heating and Air Conditioning Systems. Sheet Metal and Air Conditioning Contractors' National Association, Inc., 4201 Lafayette Center Drive, Chantilly, VA 22021.

Air Distribution Design for Small Heating and Cooling Systems. In *Systems and Equipment Handbook*, American Society of Heating, Refrigerating, and Air Conditioning Engineers, 1791 Tullie Circle, N.E., Atlanta, GA 30329.

Energy-Efficient Design of New Low-Rise Residential Buildings. Standard 90.2-1993. American Society of Heating, Refrigerating, and Air Conditioning Engineers, 1791 Tullie Circle, N.E., Atlanta, GA 30329.

HEALTH, SAFETY AND COMFORT ISSUES IN RESIDENTIAL DUCTS

Volume 2

**Better Duct Systems
for
Home Heating and Cooling**

Revision: January 16, 2001.

HEALTH, SAFETY, AND COMFORT **ISSUES IN RESIDENTIAL DUCTS**

This is the second in a series of guides intended to provide a working knowledge of residential duct systems, an understanding of the major issues concerning efficiency, comfort, health, and safety, and practical tips on installation and repair of duct systems. These guides are intended for use by contractors, system designers, advanced technicians, and other Heating Ventilating and Air-Conditioning (HVAC) professionals. This guide is recommended for anyone, including homeowners, who wants a deeper understanding of HEALTH AND SAFETY TOPICS RELATED TO RESIDENTIAL DUCTS.

The duct system, used in forced-air space-conditioning systems, is a collection of channels, rectangular, round or irregular shaped tubes that distributes the heated or cooled air to the various rooms. This system can make a big difference in both the cost and the effectiveness of heating and cooling the home. The duct system can have an important effect on health of the occupants through the unintended distribution of indoor air pollution.

This series of guides explains the operation of a duct system and the impacts of air leakage from ducts. This and other volumes in the series will focus on how you can help your customers:

- Save money
- Improve comfort
- Protect health and safety

HEALTH AND SAFETY CONCERNS IN RESIDENTIAL DUCTS

Although this manual discusses health and safety, it is not a substitute for training. Any duct-repair crew sent to a job should include at least one professional with specific hands-on training in the health and safety issues associated with ducts and with heating and cooling equipment.

Poorly designed or improperly installed duct systems can compromise health and safety. Most such problems are caused by pressure changes within the house that are induced by operation of the air handler fan. Sometimes the duct system and its fan can interact with the various exhaust fans in the house (for example, bathroom fans, vented range hoods, and clothes dryers), so it is necessary to consider the combined operation of all air movers in the house when assessing the potential for health and safety problems.

The distinction between health and safety can be a fine one. Generally, when a condition existing over a long period of time impairs the well-being of the occupants but is not an immediate threat to

life, this is referred to as a health problem. When a condition that arises unexpectedly can seriously threaten the physical condition or even the lives of the people in the building, this is considered a safety problem. The major health problems associated with ducts arise from the induction of contaminated gases, vapors, or particulates into the living space in concentrations that are unhealthy but not immediately life-threatening. Because health problems are subtle, it is not known how common they are, but there is reason to think that many duct systems create them to some degree. The most important safety problems of duct systems are the induction of potentially lethal concentrations of carbon monoxide gas into the living space (from various sources), and the possibility of flame rollout (in combustion appliances). These safety problems are not common; if they were, people would be more aware of them. Nevertheless, they must not be ignored by the professional, because when they do occur they are very serious.

An additional problem that is sometimes caused or made worse by faulty duct systems is excessively high humidity, which can result in unwanted mold growth, wood rot, and other undesirable biological organisms. In addition to damaging the appearance or the structural integrity of the building, they can also affect the health of the occupants if they become airborne.

An HVAC contractor has two responsibilities after accepting a job. The first is to find and fix any HVAC-related health or safety problems that might already exist in the house. The second is to make sure his work does not create any new ones that didn't exist before.

Causes of Health and Safety Problems

The major types of health and safety problems that are sometimes associated with duct systems and their operation are shown in Table 1. The first four are generic, while the last three only occur in systems with combustion appliances (furnaces and water heaters).

Testing for Depressurization in Zones with Combustion Appliances

Several of the above problems are related to depressurization of zones within the house which contain combustion appliances. A room or zone within the home is depressurized when its air pressure is less than the ambient (or outside pressure) or in relationship to another part of the house which is at a higher air pressure. If the level of depressurization is too great, the draft in the appliance's exhaust system will not be sufficient to overcome the pull of the low pressure zone in the room or zone containing the combustion furnace and / or water heater (hereafter called the "furnace room"). This can cause a reversal of flow in a chimney or exhaust vent which is called back-draft or reversal of flow. This is most likely to occur during the combustion appliance start-up when the exhaust system is still cold and draft has not been strongly established. This is a common cause for flame rollout in atmospheric gas appliances. Back-drafting and poor combustion may result with both oil-fired and gas-fired units of any type when the combustion air source is from the depressurized room or zone where the appliance is located. In either case, dangerous levels of carbon monoxide might enter the living-space. If back-drafting continues after the appliance has been running the problem can be very serious and must be addressed immediately. The only exception to this rule is when an appliance is

Table 1. Health and Safety Problems Sometimes Associated with Duct Systems

HEALTH/SAFETY PROBLEM	DANGER	CORRECTIVE ACTIONS
Toxins and termiticides from the ground	Radon and other toxic gases are pulled into a depressurized basement or crawl space, then into return ducts and distributed to rooms.	<ol style="list-style-type: none"> 1) Radon mitigation (if warranted) 2) Relieve basement depressurization. 3) Seal return ducts.
Fumes from stored contaminants	Vapors from stored chemicals are sucked into return ducts, or released into a <u>pressurized</u> basement (pressure causes vapors to leak into living space).	<ol style="list-style-type: none"> 1) Remove chemicals 2) Seal return ducts. 3) Relieve basement pressurization (if severe). Sealing supply ducts should help here.
Auto exhaust fumes	Return ducts in garage suck in fumes from idling car and deliver to house. (Especially in Southern homes)	<ol style="list-style-type: none"> 1) Seal return ducts. 2) Post warning sign. 3) Warn / instruct occupants.
Biological Growth	Excessive humidity promotes the development of molds and organisms causing wood rot.	<ol style="list-style-type: none"> 1) Stop moisture at source (if possible). 2) Seal return ducts. 3) Check refrigerant charge on air conditioner. 4) Downsize air conditioner.
Draft Spillage	Negative pressure in furnace room causes reverse flow in flue, spilling combustion products which are sucked into return ducts and distributed to living space.	<ol style="list-style-type: none"> 1) Relieve depressurization of furnace room. 2) Seal return ducts. 3) Install power-vented appliances.
Fireplace/Stove Backdraft	Negative pressure in room with a fireplace or wood stove causes reverse flow down chimney, spilling carbon-monoxide laden combustion products directly into the living space.	<ol style="list-style-type: none"> 1) Relieve depressurization of fireplace room. 2) Supply outside air to fireplace or stove.
Flame Rollout	Strongly negative pressure in furnace room causes sufficient reverse flow to blow fuel/air mixture from appliance into room, where it poses a fire hazard upon ignition.	<ol style="list-style-type: none"> 1) Relieve depressurization of furnace room. 2) Install power-vented appliances.

equipped with an outdoor (sealed) air intake and exhaust, commonly called a sealed combustion system. In this case depressurization will most likely cause problems, but it should not cause an immediate danger related to the combustion appliance. A simple test is therefore needed to determine the worst-case depressurization of such zones. The adjective “worst-case” is key. Operation of any type of exhaust fans located in the zone and the open or closed position of interior doors can affect the pressure in the furnace room. Since combustion appliances can come on at any time, you need to find out the most depressurized condition that can occur.

In many areas of the U.S., it is common to locate a gas- or oil-fired furnace and water heater in a basement that is essentially one big room. In these situations, a significant portion of the return ductwork is also located in this space. Return ducts often leak more than supply ducts, in part because builders are more likely to seal the supply ducts. Leaky returns depressurize the zone in which they are located (Figure 1). This can set up the problems we are discussing. The saving grace (in terms of health and safety, if not for energy efficiency) is that basements tend to be fairly leaky to the outside. This, combined with the open plan of most basements, means that even leaky ducts often generate relatively low negative pressures (one or two pascals) in the basement.

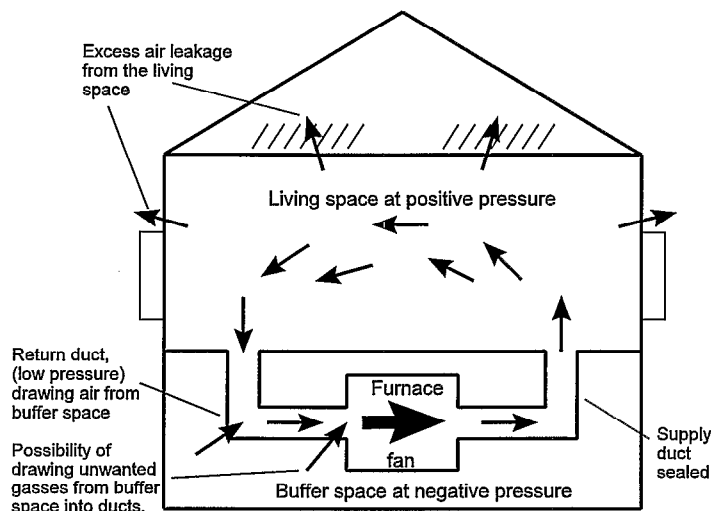

Figure 1. Duct System With Return Side leaks

Some basements are tight, however, and some systems have sealed supply ducts and very leaky returns. Either of these situations can lead to a depressurized basement. Also, it is common practice in a finished basement to place the furnace and water heater in a separate room, and this room might not be sufficiently well vented, despite code mandates (see remedies on next page). If this room encloses significant return duct leakage, there is a possibility of strong depressurization. This situation can occur even if there is very little return ductwork in the furnace room. Remember that the portion of the air handler cabinet on the inlet side of the fan is at strongly negative pressure. If it leaks, it's just like a leaky return duct.

A method for determining zone depressurization is described in VOLUME 5: TESTING AND DIAGNOSING RESIDENTIAL DUCT SYSTEMS.

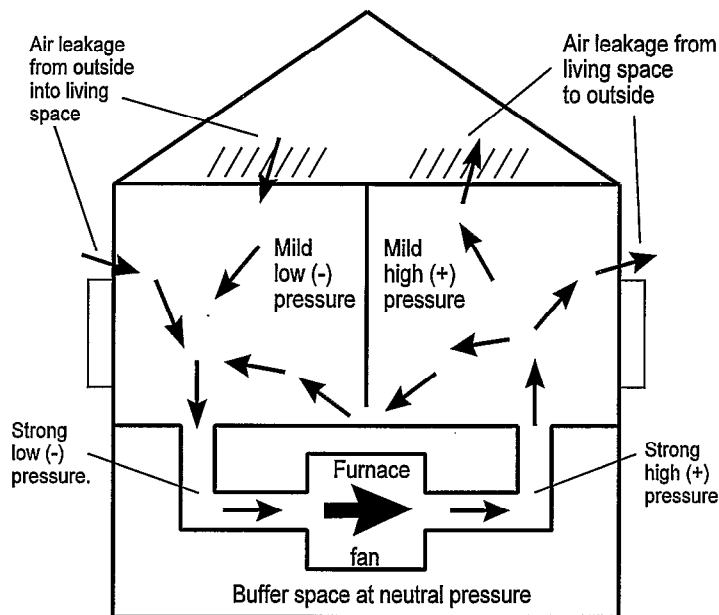

Figure 2. Excess Air leakage In The House Caused By Isolation Of Zones

Isolation of Zones Within the Living Space

Operation of the duct system may cause various parts of the living space to become pressurized or depressurized, whether or not there is an impact on the pressure in the zone containing the heating and cooling equipment. This is called isolation of zones, which can contribute to excessive air leakage and associated energy losses. It comes about when a room with a supply register but no return register is separated from the rest of the house by closing the door(s). The isolated supply register causes its room's pressure to rise because it is blowing air into the room. Pressures elsewhere in the house will generally fall. The opposite condition - depressurization - though not as common, could also occur if a room has an open return register and a closed or blocked supply register. As long as these pressures do not contribute to health or safety problems, they need not be a matter of great concern. As a general rule interzone pressure differences of more than 3 pascals should be corrected.

Isolation of zones can be confirmed by measuring the pressure difference between the section of the house with the return register and any section containing only supply registers when these sections are separated from each other by closed doors. Run a plastic tube under the door and insert its end into the input port of a digital manometer, turn the system fan on, then read the pressure difference.

Corrective measures for excessive pressure differences between zones of the living space can be taken by installing transfer ducts, louvers in doors, or cutting a strip from the bottom of the door. The impact of any such proposed solution can be previewed by gradually opening the door between the zones and seeing how much open area is required to reduce the pressure difference to 2 pascals or less.

Remedies for Furnace-Room Depressurization

If the minimum pressure in a room containing combustion appliances is more negative than minus three pascals (-3 Pa), there may be a problem. It is quite likely that sealing the duct system will alleviate it, although certain duct sealing strategies could make it worse (e.g., if supply ducts in a furnace room are sealed while leaky return ducts are left alone). This is why it is very important to do this test both before and after doing any work. If the problem existed before you entered the house, both you and your customer should know it. And if the work you did created a problem (unlikely if you follow the guidelines below) then you will know that you must deal with it before you leave.

Table 2 summarizes the recommendations depending on the conditions (if any) where a furnace room to outside pressure difference below -3 Pa was found. Note that, at a minimum, the furnace room ventilation requirements of NFPA Standard 31 (liquid fueled appliances) or 54 (gaseous fueled appliances) must be met. The recommendations below refer to possible need for ventilation in excess of these minimums.

If the furnace room is not depressurized below -3 Pa under any conditions, proceed with whatever duct repairs are justified by economic and comfort criteria. Remember if you seal supply ducts in the furnace room then the return ducts in this room should also be sealed. This is correct even if there is only a minimal effect on efficiency. Otherwise undesirable depressurization of the mechanical room might result, possibly leading to dangerous conditions including appliance vent back-drafting and related problems with the combustion appliance(s) as discussed earlier.

- **Furnace-Room Depressurization Caused by Exhaust Fans**

If the only depressurization situation is caused by operation of exhaust fans, that situation should be corrected. One example of this would be a finished basement in which a clothes dryer is relegated to the same small enclosure as the furnace and water heater. This particular problem might be cleared up by installing an additional ventilation louver between the furnace room and the rest of the basement. The proper size for this vent can be estimated by gradually opening the door between the furnace room and the finished area until the furnace room pressure has relaxed to a safe level (0 to -2 Pa). Measuring the area of the door opening required to do this determines the size of the opening required for additional ventilation.

- **System Fan Causes Depressurization**

If the pressure in the furnace room drops when the system fan is turned on, it has two likely causes, return duct leakage and isolation of zones.

The most common explanation for furnace room depressurization on system fan operation is return duct leakage in the furnace room. For this reason, when sealing the ducts, make sure that adequate

attention is paid to the return side of the system (including the air handler cabinet), even if the economic analysis doesn't seem to justify it as discussed above.

Table 2. Furnace Room Depressurization Conditions and Recommendations

Fan Settings Showing Furnace-Room-to-Outside Pressure Difference Below -3 Pa	Assessment	Recommendations
No combination of fan use produces an adverse condition	The furnace room may contain leaky ducts on both the supply and return ducts.	If you seal supply ducts, do not leave return ducts in the furnace room unsealed.
Exhaust fans only (System fan off)	Depressurization exists, but it isn't the fault of the duct system.	Customer should be informed, and you should make recommendations on how to alleviate the condition. Consider additional venting of the furnace room to the outside.
System fan only (Exhaust fan off)	The duct system is causing depressurization.	Duct sealing is almost certainly warranted, with particular attention to the air handler cabinet and return ducts in the furnace room. The other possibility is isolation of zones, a likely explanation if the effect is most pronounced when return air flows are blocked by closed doors.
Only When Exhaust Fans and System Fan are Both On	There is a cooperative effect between the exhaust fans and the system fan.	The problem may be alleviated by duct sealing. If not, additional venting of the furnace room to the outside may be needed.

If furnace room depressurization persists even after duct sealing, it may be caused by isolation of zones. You can assess the situation by looking at the configuration of open and closed doors when the furnace-room depressurization is most severe. Suspect isolation of zones as a culprit if, when the furnace-room pressure is at its most negative value, at least one room with supply register(s) but no return register has its door in the closed position. This can be tested by opening the door in question and seeing whether this relieves the pressure difference.

- **System Fan and Exhaust Fans Together**

If depressurization only happens when both the system fan and the exhaust fans are on, a combination approach to a solution may be needed. Duct sealing alone may eliminate the condition. If it not, then increasing the ventilation of the furnace room, either to the outside ambient air or to the rest of the basement (if applicable) is a possible solution.

Severe depressurization of the furnace room (-6 Pa or worse) may lead to flame rollout in certain types of equipment, such as atmospheric gas burners. In such circumstances it is especially important to relieve the condition. If the heating equipment needs to be replaced, consideration should be given to specifying power-vented models or models designed with sealed combustion. Note however that both the space-heating and water-heating functions must be included in such a strategy.

Obviously, it will be necessary to repeat the depressurization test when all work is completed including replacement of the furnace when needed. If a depressurization condition persists, it will need to be corrected and checked with yet another depressurization test.

Fireplaces and Wood Stoves

If the home has a fireplace or wood stove, the room in which it is located should be tested for depressurization by treating this room as if it were the furnace room. The customer can also be asked about evidence of chimney backdrafting. If ashes are blown into the room after the fire dies down, or if the customer complains of physical symptoms associated with the use of the stove or fireplace, then special attention should be paid to chimney backdrafting. The use of a CO monitor in any room containing a stove or fireplace is recommended as additional protection.

Remedies to fireplace or wood stove room depressurization include: 1) relieving the negative pressure through venting and 2) supplying outside air to the fireplace or stove. If there is significant return ductwork in this room (as there might be, for example, in a finished basement) it can be sealed. If opening a door between this room and another part of the house solves the problem, a louvered opening might be the answer. The details of these remedies (other than sealing return ducts) are beyond the scope of this manual (see NFPA-211), but the contractor should be aware of them nevertheless.

Other Health/Safety Problems

Most of the discussion so far has involved combustion appliances, but important health or safety problems can arise regardless of what kind of heating and cooling equipment is used. One is the induction of toxic and flammable vapors and particulates into return ducts located in a basement, garage, or other enclosed space where chemicals are stored. A similar one is the induction of automobile exhaust from a garage in which the air handler is located. The general solution to these problems is twofold: eliminate the source, and seal the return ducts and air handler cabinet. Toxic or flammable chemicals stored in the home should be minimized. Those that must be kept could be

stored in a detached garage, storage shed or other area that is far removed from any of the home's ductwork. Another solution is an enclosed cabinet with an outside air vent. In the case of automobile exhaust, the homeowner should be warned not to leave the car running in the garage, even when the overhead door is open. A warning sign can also be posted. A carbon monoxide detector can also be installed to alert the homeowner of problems associated with a build up of this odorless and colorless gas in the garage. Carbon monoxide can not be directly detected by humans until its harmful effects start to be felt. Leaking return ducts, furnace or mechanical air handler can be a dangerous problem if not corrected (Figure 3). Be aware also that leaky return ducts in a zone (such as an attic) that is in communication with the garage can cause the same problems, even if the garage itself has no equipment or ductwork. Such inter-zone linkage may not be obvious. Combined with these warning actions, sealing the return ducts, with special attention to runs in the affected zones, should greatly reduce the probability and severity of any health hazards. The customer should, of course, be fully informed of the required actions and the benefits of following them.

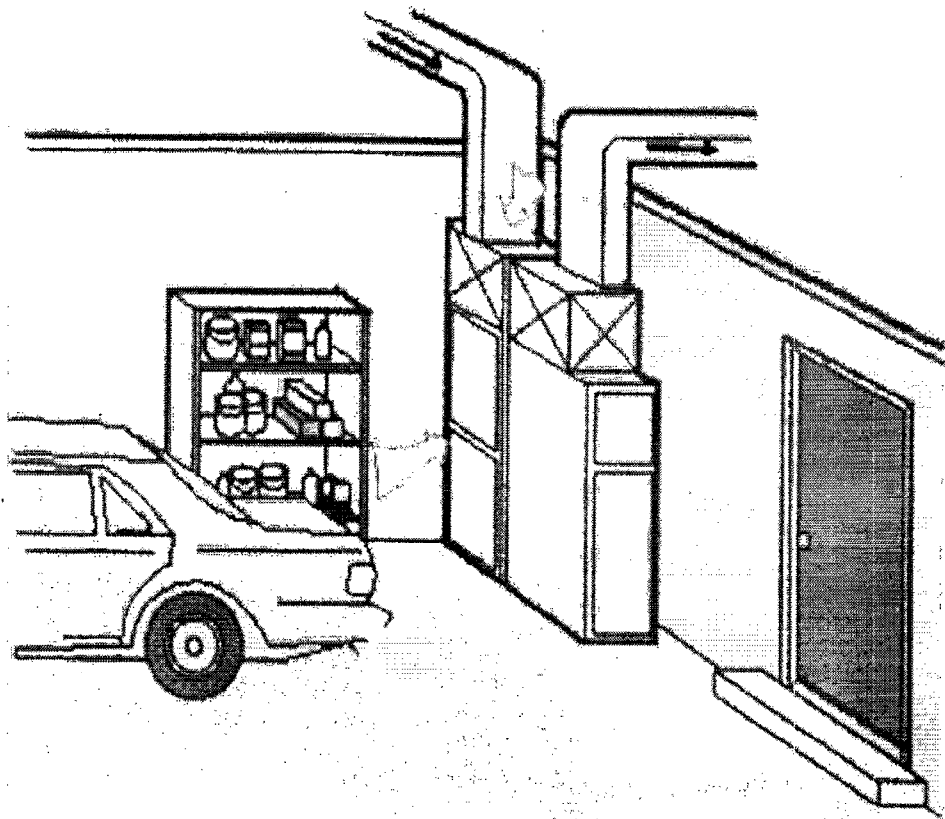

Figure 3 Ducts, Furnaces and Air Handlers Located in the Garage Should be Well Sealed (Graphic Credited to Energy Source Builder, December, 1995)

Generally, it is not a bad thing if a basement is somewhat pressurized. Chances are that excessively high positive pressures in a basement are indicative of supply duct leakage, and will be relieved by duct sealing.

Excessive humidity is a common problem in houses located in southern and coastal climates. Often it is assumed that the air conditioner is at fault. Sometimes it is. Things to look for on the equipment side are improper refrigerant charge and excess capacity due to gross oversizing. However, the duct system may be the cause. This is especially likely if testing reveals significant return leakage from the outside. Customer complaints of damp inside air combined with evidence of mold growth or wood rot within the conditioned space should be a “red flag” requiring a through check for return duct leakage.

References on Health and Safety

NFPA-31. Standard for the Installation of Oil-Burning Equipment. National Fire Protection Association, P.O. Box 9101, Quincy, MA 02269-9101.

NFPA-54. National Fuel Gas Code. National Fire Protection Association, P.O. Box 9101, Quincy, MA 02269-9101.

NFPA-211. Chimneys, Fireplaces, Vents, and Solid Fuel-Burning Appliances. National Fire Protection Association, P.O. Box 9101, Quincy, MA 02269-9101.

THERMAL COMFORT

If a customer has a complaint of inadequate heating or cooling with a forced-air system, there is a good chance that the duct system is responsible. Sometimes the problem affects the whole house. In other cases it is confined to one or two rooms.

Comfort problems caused by ductwork can be divided into two broad types: those that cause unsatisfactory heating, cooling, or dehumidification over the entire house, and those that only affect certain rooms.

Inadequate Cooling Capacity

A problem found fairly often in hot climates is insufficient cooling capacity at the peak-load condition. This problem is most commonly seen in homes with attic ductwork. Attic ducts are more common in the South and Southwest than in any other region of the U.S., largely because slab-on-grade construction is so popular in these regions. With this foundation type, the attic is the most convenient place to put the ducts.

Attic air tends to be much hotter than outside ambient air. Duct leakage in attic return runs can cause large volumes of hot, humid air to be sucked into the system. This places an extra load on the air conditioner, reducing the remaining capacity that is available to cool the house. Supply-side leaks and poor insulation then cause much of the remaining capacity to be wasted. The available capacity, after deducting the “taxes” imposed by duct losses, is often insufficient to meet the peak cooling load even if the air conditioner runs continuously.

The traditional answer to this problem has been to install a larger air conditioner, but in the last decade it has become clear that a better answer is often to fix a duct system that either was poorly designed and installed or has degraded over time.

Poor Humidity Control

Even if the air conditioner is able to maintain desired temperature levels, humidity control may be inadequate. Poor humidity control is especially likely when the air is moist but temperature levels are moderate. In such cases, the air conditioner may satisfy the thermostat long before the latent load has been met, and a cool, damp condition persists in the home, possibly leading to mold and mildew growth and wood rot (see Figure 4). Besides being uncomfortable, this can destroy clothing and other items stored in closets, as well cause serious cosmetic and structural damage to the house itself.

Humidity problems are not always found in the least efficient systems. Compare, for example, a house with leaky supply and return ducts in the attic with a second, nearly identical structure with crawlspace ducts whose only flaw is leaky returns. The distribution efficiency for the first house will probably be poorer than in the second, especially at peak-load conditions. But for that very reason, the air conditioner in the first house will probably run so many hours to meet the cooling load that humidity will be adequately controlled. In the second house, however, little cooled air is lost on the supply side, and the air that leaks into the return ducts, although it is moist, is drawn in from the relatively cool crawlspace environment. Thus, in the second house, the duct leakage contributes significantly to the latent cooling load but very little to the sensible load.

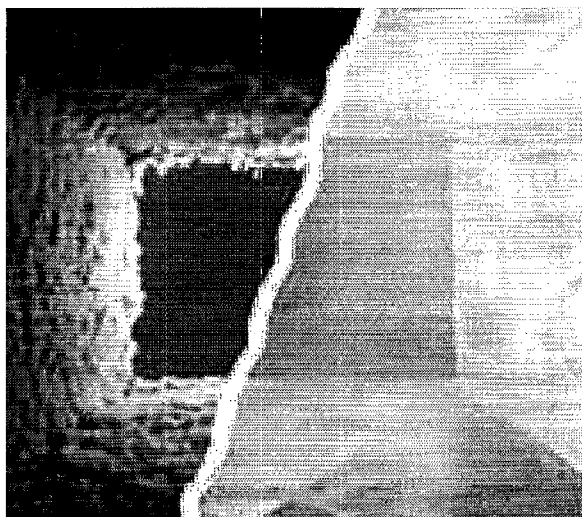

Figure 4 Dust, dirt in the presence of high humidity and moisture can lead to mold and mildew growth in ducts.

Figure 5 illustrates this contrast. This example shows that a relatively good number for distribution efficiency, as calculated by ASHRAE Standard 152, does not by itself rule out a need for duct repair. Remember, Standard 152 considers energy losses in ductwork but does not directly address thermal comfort. Return duct leakage is a key thing to consider in humid climates when diagnosing thermal comfort problems, whether these take the form of inadequate cooling capacity or poor humidity control.

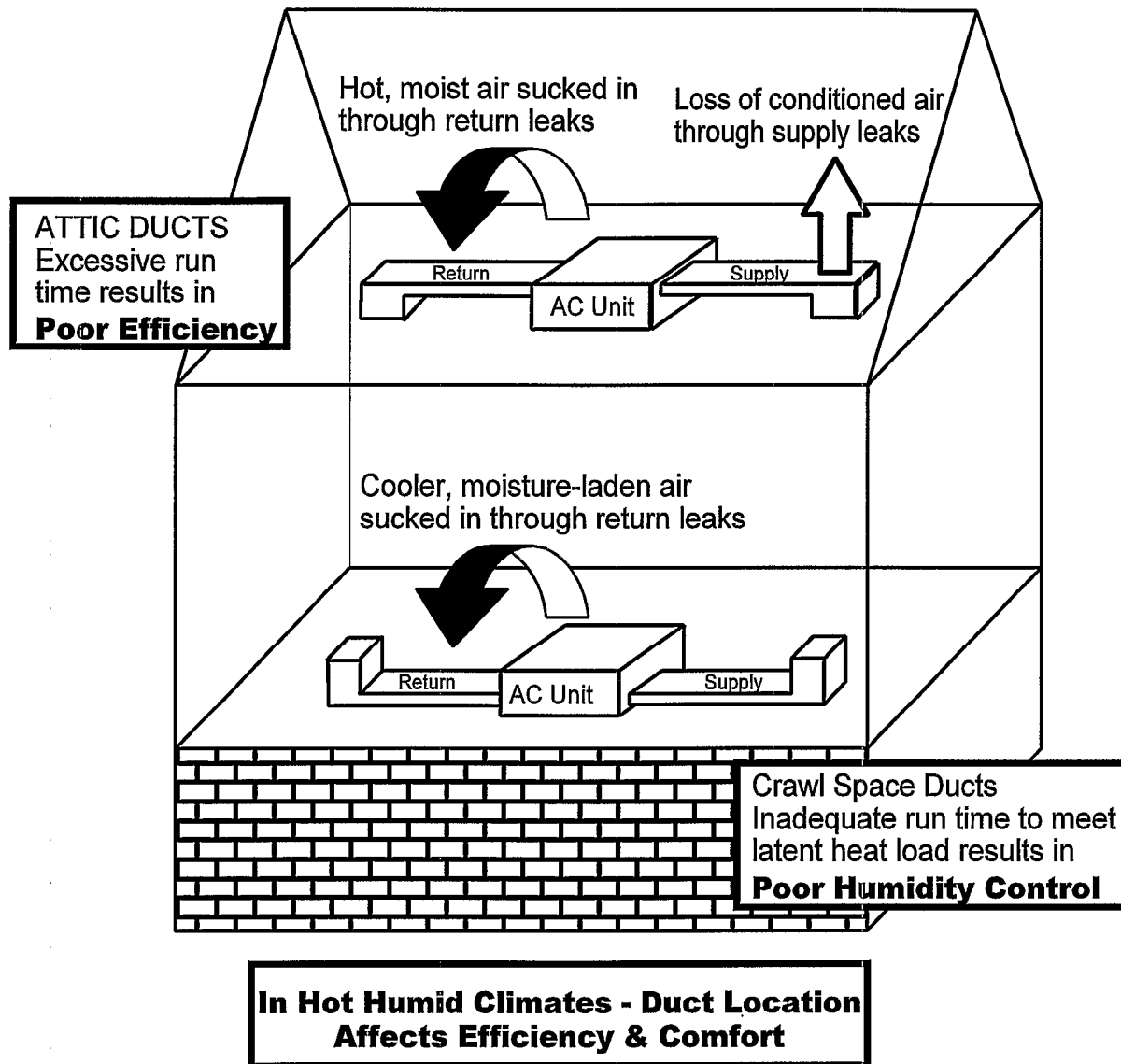

Figure 5 Common efficiency and comfort problems contrasted for attic and crawl space ducts in hot humid climates.

Finally, it must be recognized that not all humidity problems are caused by duct leakage. In some cases, there will be an identifiable source of water vapor that needs to be corrected, either by eliminating the source or by blocking the path by which the moisture makes its way into the house. If there is an identifiable source of moisture, such as a wet basement or crawl space, that is really the first thing to correct. However, if the source cannot be identified or blocked, and if the moisture problem persists even after the ducts have been repaired and the refrigerant charge has been corrected, the next step will depend on whether the air conditioner is due for replacement. If it is, first make sure the new unit is properly sized. Next, consider adopting one of the newer air-conditioning technologies that stress dehumidification. One approach involves the use of a reduced air-flow rate over the indoor coil. This involves an energy penalty, because the indoor air is cooled to a lower-than-usual temperature, but it can increase the amount of dehumidification provided. The installer should, however, take care to remain within the manufacturer's guidelines in setting up the system, to avoid unintended consequences such as coil freeze-up. Another approach, which can actually be quite energy efficient, uses an indoor coil with a wrap-around heat-pipe unit that effectively "trades in" some of the sensible cooling (i.e., temperature reduction) for an equivalent amount of dehumidification.

If the equipment cannot be replaced and the moisture problem persists even after the ducts have been repaired, the refrigerant charge has been brought to the proper level, and all reasonable efforts have been made to stop or block any identifiable sources of moisture entering the building envelope, one can fall back on the obvious solution of installing a dehumidifier in the portion of the conditioned space where the moisture problem is most severe. Because this approach is so obvious, it is often the first thing tried by home repairers confronted with the unpleasant and often frightening effects of excess moisture in the living space. It should be viewed as a desperate last resort, though, because it is very energy inefficient. The latent heat energy represented by the water vapor that is removed must first be processed by the dehumidifier. That energy plus the heat generated by the dehumidifier's compressor must then be processed by the central air conditioner for removal from the living space.

Turning to the heating mode, excessively dry indoor conditions can be caused by duct leakage. The relative humidity of air drops precipitously when it is warmed, even though the amount of water vapor in the air remains the same. For example, if the relative humidity of an air mass at 20 °F is 50%, it drops to less than 10% when the air is warmed to 70 °F. If the return ducts leak significantly, they can pull in large amounts of cold, dry air, which is then delivered to the conditioned space. If supply leakage dominates, the house itself will be depressurized, and this may boost the infiltration of dry air directly into the house. Either way, duct leakage can lead to excessive winter dryness in cold climates.

Poorly Conditioned Rooms

The above problems had in common the characteristic that they affect the whole house. It sometimes will be the case, however, that poor conditioning is restricted to one or two rooms. Often these will be the rooms at the ends of the longest duct runs. Poor conditioning of a room may simply be the

fault of the original duct design. The run to the room in question may be too small for its length or it may have so many inefficient bends and fittings that the air flow is reduced to a level that would be inadequate even if there were no duct losses. It's likely, though, that leakage and conductive losses will aggravate the problem.

The bright side of this is that a customer's first impression after a duct repair job will often be that a room that was always too cold in the winter or inadequately cooled in summer will now be comfortable.

In sizing up the likelihood that a duct repair will solve a cold- or hot-room problem, the following steps can be taken. They should usually be done in the order listed, starting with "eyeball" inspection followed by temperature and pressure-pan tests. These will usually be enough to diagnose the problem, but if uncertainty remains, register air flow measurements can help to clarify the situation.

- **Check for the presence of fittings that greatly reduce flow.**

These include square takeoffs from trunk to branch, hard 90° bends, abrupt transitions, and sagging or serpentine sections of flexible duct. Internal obstructions, such as closed dampers, should also be checked for.

Example: a homeowner complained that a front bedroom was always cold in the winter. Inspection revealed that the house was divided into two zones by a damper system, and in order to include this bedroom in the sleeping zone the builder had installed two hard 90° bends with square elbows, one immediately after the other, in an attempt to get the air to make a 180° turn. In this case the system's resistance to air flow was reduced by substituting two radius elbows with turning vanes.

- **Check the insulation status of the duct run serving the cold room.**

If the run is uninsulated, adding duct wrap may alleviate the problem, especially if the run is long.

Example: a room that homeowners indicated was chronically cold in winter was found to be served by a duct that had its insulation removed for an unknown reason and never put back. The fact that the other runouts were insulated put this one at a disadvantage. The first guess that the lack of insulation was causing the problem was then tested by making temperature measurements at the registers. (See below.)

Once such "eyeball" clues have been looked for, the next step is to make some measurements.

- **Check the temperatures of air coming from the supply registers.**

This can be done with a thermocouple reader or, to save time, with a hand-held infrared temperature sensor that can be pointed at each register in turn. In the heating mode, if the supply-register

temperature is significantly less in the cold room than in other locations around the house, the duct leading to this room is probably the culprit. (Check for an unusually *high* delivered air temperature in the cooling mode.) This test is best for detecting excessive losses via conduction, which would arise from a duct that is exceptionally large in surface area or poorly insulated. It cannot be relied on to say much about leakage.

Example 1: For the situation described in the preceding paragraph, the delivered air temperature at the cold room's supply register was less than 100 °F, whereas all the other registers were delivering air above 120 °F. After this runout was insulated to R-4 (the same as all the others) its delivery temperature went up to 118 °F. That solved the problem.

Example 2: In a home with 12 supply registers, the measured delivery temperatures after 10 minutes of furnace on-time were 121, 126, 133, 144, 108, 129, 132, 119, 127, 125, 135, and 123 °F. Before these measurements were made, the homeowner complained that one room was always cold in the winter. It turned out that this room was the one with the 108 °F supply-air temperature. It was the second-longest duct in the house. The longest one had a 125 °F supply-air temperature. The supply trunk and all the runouts were insulated to R-4. Although thermal losses from this duct were likely to be associated with the problem, it was something of a puzzle why this duct had such a low delivered-air temperature when an even longer one did not seem to have the same difficulty. (See the next paragraph for more clues.)

- **Do a pressure-pan test.**

This will help to assess whether there is significant leakage in the duct run serving the room. A pressure pan test requires the house to be pressurized to 25 Pa. Therefore it is most easily accomplished when a blower door test is being performed on the house envelope.

What's a blower door? It's an adjustable-speed fan that's placed in an outside doorway of the house (see Figure 6). It's main purpose is to measure the airtightness (or lack thereof) of the external envelope of the house. The open space of the doorway not occupied by the fan is blocked off by a plastic/fabric barrier held in place by an adjustable frame. The idea is to see how much air you have to blow into a house to maintain a given pressure difference between the inside and outside. The more air flow that's required to maintain this pressure, the leakier the house envelope is and the more air infiltration you'd expect. Too much air infiltration adds unnecessarily to heating and cooling loads.

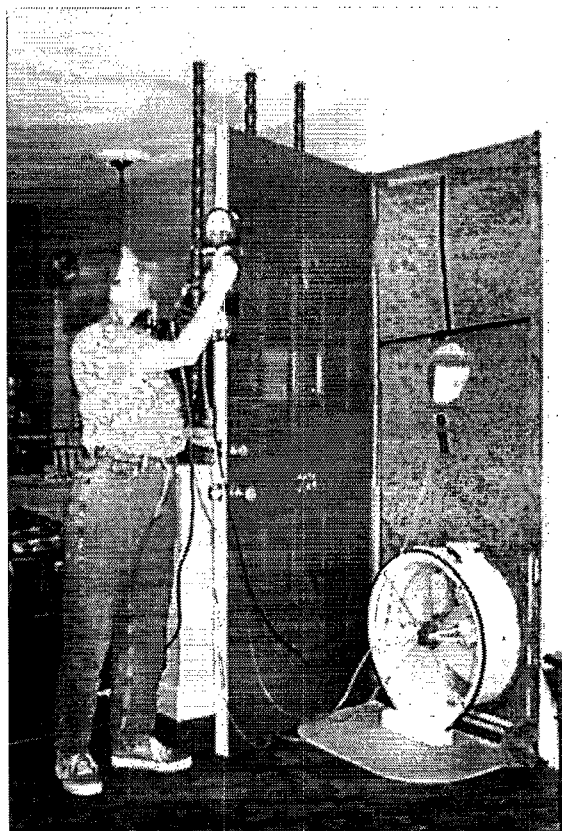
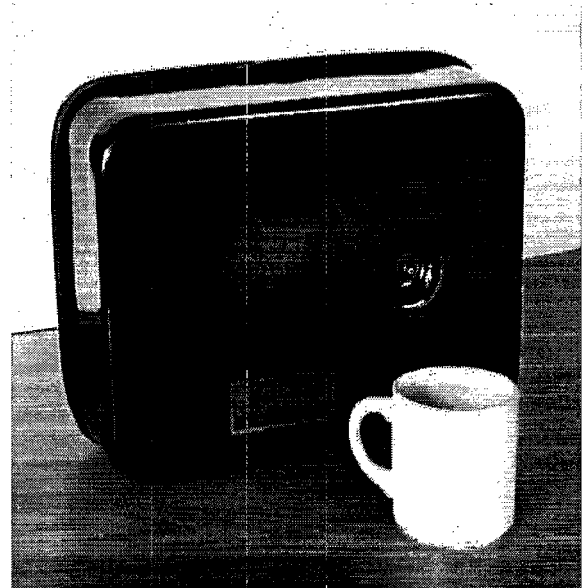

Figure 6 Blower Door In Use

So what's a pressure pan? Think of an ordinary baking pan placed (Figure 7) over a register. A digital pressure gauge is connected via a plastic tube to a fitting on the back of the pan; this permits easy measurement of the pressure difference across the pan. While the blower door is pressurizing the house to 25 Pa, place the pressure pan (Figure 8) over the register serving the cold room and measure the pressure difference across it. A value of zero indicates an airtight duct, while the maximum possible 25 Pa indicates a large open hole right at the register. Then do the same for several registers in other rooms. If the cold room has a much higher reading than the others, this is an indication that duct leakage is high in the runout leading to the room.



Figure 7 Pressure Pan Test



**Figure 8 Pressure Pan
Tube Connector on Right Side**

The proper use of the blower door and pressure pan is described further in VOLUME 5: TESTING AND DIAGNOSING RESIDENTIAL DUCT SYSTEMS.

- **Measure the air flow from the register with a flow hood.**

A flow hood (Figure 9) can be used to measure the rate at which air flows through any register. Its use in diagnosing cold room problems is as follows. The air flow rate into the cold room is measured with the flow hood and divided by the room area in square feet. This result is compared with a similar number for the whole house, obtained by dividing the air flow through the furnace by the total of all heated areas of the house in square feet. If the ratio for the room is about half of that for the house, or less, insufficient supply air is probably a major cause of the problem.

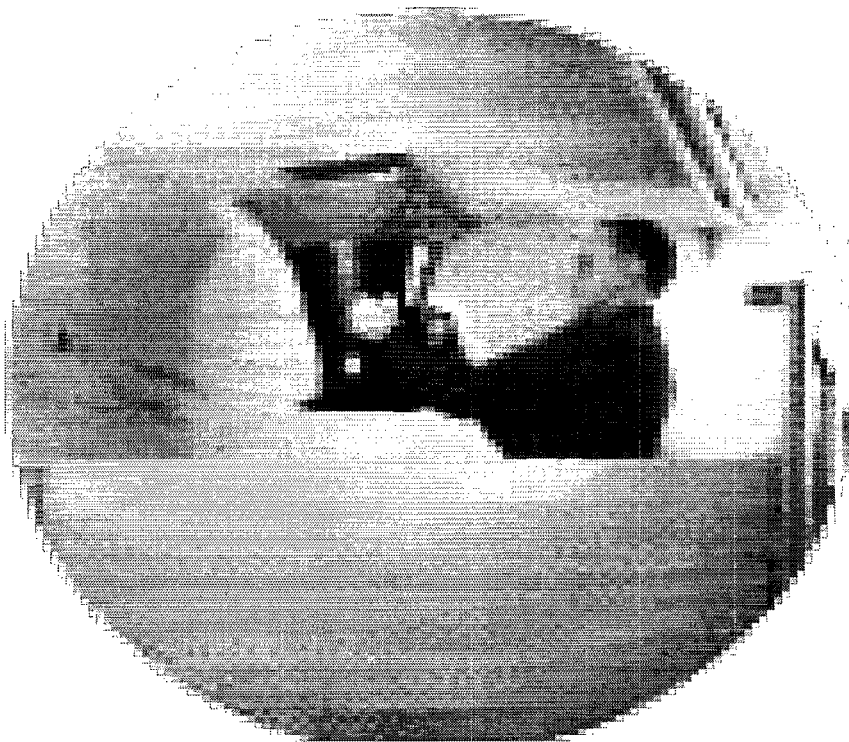

Figure 9 Flow Hood Used To Determine Output From Register

Photo Credit: Alnor Instrument Company

Example: a cold room with a single supply register was found to have 40 cfm of supply air for a room area of 175 ft². The conditioned area of the house was 1950 ft², and the measured fan flow rate was 1050 cfm. Taking the cfm/ft² for the house (1050/1950) gave 0.54 cfm/ft² as a benchmark. Calculating cfm/ft² for the room yielded 40/175, or 0.23, less than half as large. Low air flow was probably a major cause of the problem.

Too-Low Delivered Air Temperature with Heat Pumps

In heat pump systems the delivered air temperature is usually quite a bit lower than it is with most furnaces. This is because the efficiency of a heat pump is maximized if the condensing temperature is kept low, whereas the efficiency of a furnace is not affected very much by the temperature of the delivered air. Heat pumps generally deliver air to the supply plenum at 85 to 110 °F. Most furnaces usually send out air at 120 °F or above. Consequently, a heat pump system has much less leeway than a furnace for temperature drops in the ducts before customers begin to feel drafts or complain that the heat pump is delivering cold air to the room.

Heat-pump systems can be diagnosed in the same manner as described in the third bullet of the previous section. Measure the delivered air temperature at all the registers and give special attention to the ducts leading to registers where this temperature is near the low end of the range.

Thermal Comfort Summary

If the customer identifies a room, rooms, or the whole house as being chronically under-conditioned, you can generate significant goodwill for your firm if you solve the problem and explain how you did it. Although you can always install a larger air conditioner or an auxiliary heating or cooling unit serving a poorly conditioned room, you will save your customer a “ton of money” if the cause is the ducts and you address that problem instead.

CUSTOMER BENEFITS FROM BETTER DUCT SYSTEMS

Volume 3

**Better Duct Systems
for
Home Heating and Cooling**

Revision: January 16, 2001

CUSTOMER BENEFITS FROM BETTER DUCT SYSTEMS

This is the third in a series of guides intended to provide a working knowledge of residential heating and cooling duct systems, an understanding of the major issues concerning efficiency, comfort, health, and safety, and practical tips on installation and repair of duct systems. These guides are intended for use by contractors, system designers, advanced technicians, and other heating, ventilating, and air-conditioning (HVAC) professionals.

This volume discusses several ways in which better duct systems can provide customer benefits. Emphasis is placed on synergies among the various benefits and on opportunities for combining duct upgrades with other installation, replacement, repair, or maintenance activities where the HVAC professional already has the customer's attention.

RESIDENTIAL DUCT SYSTEMS TODAY

Ducts are used in the heating and cooling systems in about 50% of the homes in the United States today. This percentage is constantly increasing. In new construction the proportion that utilize ducts is closer to 90%. The homebuilding industry has gravitated toward ducted (forced-air) systems because of the ease of including central air conditioning in the system, the relatively low cost of ducts, and the convenience of minimizing the number of interactions between trades.

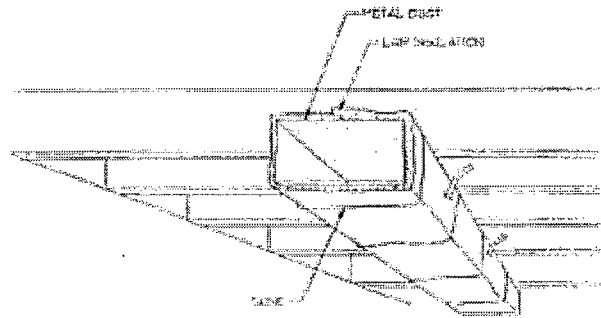

Figure 1 Typical Modern Residential Duct

No one disputes that forced-air heating and cooling can be made to perform extremely well, delivering high levels of comfort and efficiency. However, research over the past decade has shown that duct systems, as actually installed, often perform far below expectations in both of these areas. Moreover, in a small but significant proportion of cases, design flaws and/or hasty installation may give rise to health and safety concerns.

- **Efficiency**

Test measurements on existing residential duct systems in vented attics and crawl spaces have shown that, typically, they may lose 25 to 40 percent of the heating or cooling energy put out by the central furnace, heat pump, or air conditioner. Homes with ducts in a protected area such as a basement may lose less than this, while some other types of systems (such as attic ducts in hot, humid climates) often lose more, especially under peak-load conditions. Duct systems lose energy in two ways:

1. conduction of heat through duct walls;
2. leakage of air through holes and joints in the duct system.

These losses may be increased by pressure changes in the living space caused by operation of the central air handler fan. The basics of how duct systems operate and the reasons why energy performance is often sub-par are discussed in Volume 1. Volumes 4 through 6 discuss ways of improving efficiency in both new and existing duct systems.

- **Thermal Comfort**

Thermal comfort is often an issue in duct systems.

Common comfort problems include:

1. Inadequate cooling capacity;
2. Poor humidity control;
3. Rooms that are excessively hot or cold.

Volume 2 discusses ways in which duct repairs can alleviate many of these comfort problems.

- **Health and Safety**

In most industries in the developed world, health and safety issues have loomed ever larger in customer's minds in recent years, and will likely continue to do so. The HVAC industry is no exception. Volume 2 discusses some health and safety issues that have been raised with duct systems and Volume 5 includes some simple checks that you can do. These will enhance your customer's peace of mind and increase their confidence in all aspects of your work.



Figure 2 Efficient Quality Ducts – A Key To Health, Comfort & Economy

OPPORTUNITIES IN EXISTING HOMES

Although improved duct efficiency by itself can often justify repair of a leaky, poorly insulated system, four **Golden Opportunities** for enhanced benefits should always be looked for.

Lower energy costs are the *bedrock* on which the case for duct repair should usually be based. There are, however, at least four situations in existing homes that HVAC contractors should look for, where customer benefits will be even more attractive than the duct efficiency numbers alone would indicate. We call these situations the **Golden Opportunities** for duct repair.

- **Comfort, Safety, and Health Enhancements--Golden Opportunity Number One**

When ducts are repaired, any improvement in thermal comfort will be noticed immediately. All other benefits come later, by which time the customer's attention may be riveted elsewhere. For this reason a specific comfort improvement should be looked for wherever possible.

The main comfort improvement in duct repairs stems from improved delivery of conditioned air, especially to rooms that are at the end of long duct runs. Excessive leakage in a particular duct run may lead to the room it serves being too cold in winter and too hot and humid in the summer. The problem may be compounded if insulation R-values are low or nonexistent. Sometimes the existing system will be so bad that the whole house is poorly conditioned, not just one or two rooms. The customer will notice the improved space conditioning immediately following the duct repair job and will often consider this benefit alone to be worth the entire cost of the work.

Health and safety concerns arise from the possibility of sucking undesirable gases and vapors into the duct system and thereby delivering them to the living space. The nature of these concerns and how to deal with them are discussed in Volume 2. The intent here is not to indulge in *scare tactics*, but rather to eliminate any potential problems before they occur and thereby to enhance the customer's peace of mind.

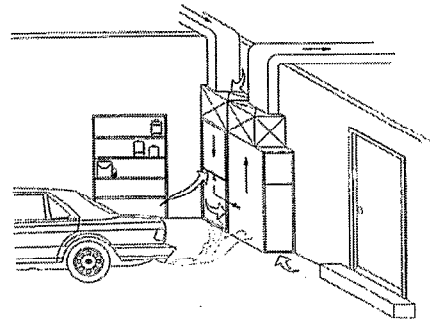

Figure 3 Stress Health/Safety In Presentations Not Scare Tactics

- **Improving the Efficiency of Heat Pumps--Golden Opportunity Number Two**

Volume 1 has already mentioned the extra efficiency improvement that duct repair can provide to heat-pump systems. To summarize, improved duct efficiency reduces the heating load at any given outdoor temperature, and thereby lowers the balance-point temperature--the outdoor temperature at which the heating load just matches the capacity for compressor-driven heating. More of the load is then met using compressor heating, and less using electric resistance backup. This improves the seasonal efficiency of the heat pump because resistance heat is much less efficient than compressor-driven heating. And remember, this benefit is over and above the benefit from reduced duct losses themselves.

It should also be noted that heat pump systems are especially good candidates for thermal comfort improvements. As is well known, the delivered air temperature in heat pump systems (in the heating mode) is usually designed to be considerably lower than it is in systems served by furnaces, because the efficiency of a heat pump declines rapidly with increasing condensing temperature, whereas a furnace's efficiency depends far less on its output air temperature. Starting with a lower supply air

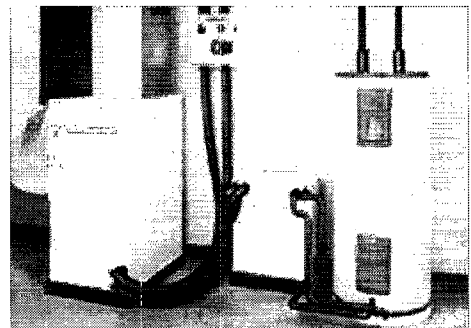

Figure 4 Typical Ground Coupled Heat Pump Installation

temperature than a furnace, a heat pump system is particularly susceptible to the cold-room syndrome, and also to sensations of draftiness if the air leaving the supply register is cool and dry enough to extract heat energy from the skin by evaporation. Consequently, systems served by heat pumps are especially promising for duct repair efforts.

This discussion applies both to air-source heat pumps and to the increasingly popular geothermal (earth-coupled) heat pump systems. None of this negates the benefits of duct repair in systems with furnaces. It's just that with heat pumps you get an extra payoff from better ducts!

- **Attic Ducts in Hot, Humid Climates--Golden Opportunity Number Three**

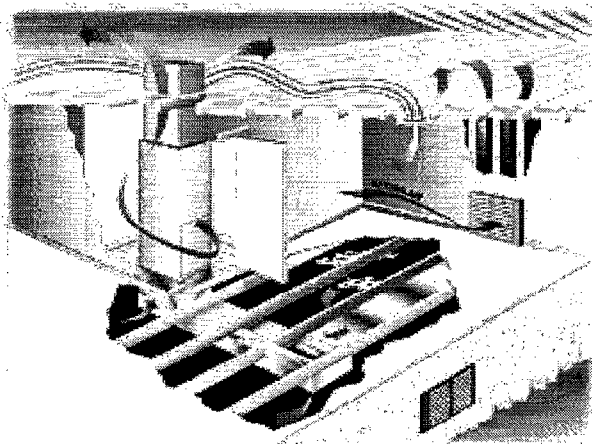

Figure 5 Leaky Attic Ducts In Hot Humid Climates Translates To A Golden Opportunity For Energy Savings For Consumers!

Much of the research on duct system efficiency has been done in the state of Florida. This work has shown how much energy can be lost by leaky or poorly insulated ductwork in a hot attic. Unfortunately, because so much residential construction in the South is slab-on-grade, builders in this region tend to choose the attic as the most convenient place to put ducts. Leaky return ducts are especially problematic in these systems, because they suck in humid air that is usually even hotter than the air outside. This reduces the capacity of the air conditioning system to cool the house, sometimes to the extent that it may be unable to meet the load even running full-time. Customer complaints that the air-conditioning system is not providing adequate cooling have

often been dealt with by installing a larger unit. However, the culprit is often the duct system. Fixing a leaky duct system and adequately insulating the ducts will not only save large amounts of electricity, but will generally result in a more comfortable environment in the home.

It should be pointed out that the efficiency of an attic duct system in a hot, humid climate tends to be lowest under peak-load conditions. This is the worst possible case, not only from an efficiency standpoint, but also because it reduces the effective capacity of the system. A 5-ton system that is 40% efficient at peak load (not an unusual number) behaves on peak days as if it were a 2-ton system. Complicating the problem is that on cooler days the efficiency will be higher, which just makes the system more oversized. Oversized systems tend to do a poor job of controlling humidity. The moral of this tale is simple. When the system can't cool the house, make the ducts your prime suspect.

- **Duct Repair on Equipment Replacement--Golden Opportunity Number Four**

From the HVAC contractor's point of view, the single best opportunity to interest a customer in duct renovation is when a furnace, heat pump, or air conditioner needs replacement. There are two main reasons for this. First, the contractor is already on site, so the costs of finding the customer and of travel to the job are already paid. Second, the best choice of replacement unit will often be influenced by the condition of the duct system. If the unit is simply replaced with another just like it, the customer is deprived of a triple opportunity for cost effectiveness and comfort that will not come around again until the new appliance has completed its service life.

What is this triple opportunity? Simply put, it consists of the following benefits:

1. Upgraded equipment efficiency, with lower fuel costs.
2. Better duct performance, with still lower fuel costs and improved thermal comfort.
3. Reduction in size and cost of the replacement equipment.

When new equipment is needed, the availability of the first benefit should usually be obvious. The second benefit, improved duct efficiency, is available whether or not the equipment needs to be replaced. It is the third benefit that needs to be sold.

A simple example will illustrate the case. Suppose a 3-ton air conditioner has failed. Should we just replace the unit or should we repair the ducts, too? In order to arrive at a proposal that is in the customer's best interest, the contractor should consider the following:

What will the customer's cost be for a duct-repair job, and how will this compare with the annual energy savings?

Will the duct repair allow a smaller unit to be used, and how much of a first-cost saving will this provide?

Should the new unit have the minimum efficiency permitted according to the national standards, or should a more efficient one be chosen?

In one example case, it was determined that if the ducts were repaired, a 2-ton unit would be adequate, whereas if they were not repaired, a 3-ton replacement unit would be required. The contractor priced his services as follows:

- A proposed duct repair package was priced at \$900.
- A 2-ton unit would be \$500 less than the comparable 3-ton unit.
- Fixing the ducts would save \$200 per year in fuel costs.

This information permitted a quick calculation of a simple payback time for the duct repair. The net cost of the retrofit was \$900 minus the \$500 savings for the smaller equipment, or \$400. Saving \$200 annually thus would pay back this incremental investment in two years.

The economics of duct repair are helped considerably by the savings on the smaller unit. If the equipment did not have to be replaced, the payback time would be \$900 divided by \$200 or 4.5 years. This is still an attractive investment for most customers, but 2 years is even better.

Note once again that, for many customers, the dollar savings will be merely the *frosting on the cake*. Once they realize the thermal comfort, health and safety benefits of a good duct system, they may be willing to accept that there will be dollar savings and let it go at that. Other customers will want the numbers, so it will pay to be able to provide them.

Once the duct repair decision was made, the efficiency of the new air conditioner needed to be selected. This would logically be done in a manner similar to the above, by evaluating the additional savings a better unit could provide and rating that against the additional cost of such a unit.

Finally, in this example, if the furnace, though operating, has poor efficiency and is well along in its expected service life, consideration should be given to replacing it also and presenting the customer with an essentially new heating and cooling system with good ductwork. This latter choice will, of course, depend on the customer's ability to carry the cost of repairing the ducts and replacing a furnace and an air conditioner units at the same time.

OPPORTUNITIES IN NEW HOUSING

In new construction, the details in the design of a duct system are still open to change. This presents an opportunity that is generally not present in existing buildings. The flip side of this, however, is that once this opportunity is squandered through a *business as usual* installation, it can never be regained. Research has shown that existing duct systems located in vented attics and open crawl spaces will typically lose 25% to 40% of the heating or cooling energy input to them by the equipment. This is the same as losing one-third to two-thirds of the underlying loads. It is extremely important, therefore, that the builder and HVAC contractor collaborate to choose the most attractive option for the potential home buyer.

- **Generic System Choices**

The first system choice that has to be made concerns the type of distribution system to be used. Ducts are by far the most popular choice among builders. Installed in nearly 90% of new houses, ducts are relatively low in cost, are easily adaptable to both heating and cooling, and allow the contractor to minimize the number of working trades involved in the installation. The scope of this manual is limited to ducted systems. This is by no means intended to discourage a careful consideration of other options.

Assuming that a ducted system has been chosen, the next generic choices relate to the location of the duct system within the building, the type of system layout, and the level of sealing and insulation to be employed. As was explained in Volume 1, the possible location choices for a duct system can be ranked according to the extent to which heat (or cooling) lost from the ducts is effectively regained.

Placing the ducts in the conditioned space is the most efficient choice. Duct energy losses can be eliminated if unintended leakage paths to the outside are carefully avoided. Even better, with ducts in the conditioned space, the health, safety, and comfort problems discussed in Volume 2 are unlikely to arise. Despite this, at least four impediments stand in the way of widespread use of conditioned-space ductwork:

1. Difficulty of hiding ductwork;
2. Perceived extra cost;
3. Need for the building designer to get involved with the details of duct design;
4. The scheduling of trades on the job is likely to be somewhat different.

Whenever these difficulties prevent the placement of ducts in the conditioned space, the next best choice should be considered. This is to reduce duct energy losses to a practical minimum through good practice. Good practice has the following elements:

Design the total heating and cooling system using a reliable method such as that embodied in the Air Conditioning Contractors of America (ACCA) Manuals J, S, and D.

Minimize the surface area of ducts outside the conditioned space through good routing, use of low-loss fittings, and (where feasible) placement of registers near interior walls.

Specify suitably low levels of air leakage to/from the outside and include a post-installation leakage test in the construction plan. As a benchmark, it is suggested that air leakage to/from the outside should not exceed 5% of total air flow on either the supply or return side.

Require that ducts be sealed using materials and techniques that will last as long as the ducts. If the ducts are sealed by hand, UL Listed (not UL Classified) mastic should be used. Automated sealing may also be considered. (See Volume 6.)

Insulate ducts outside the conditioned space, at least to R-6 and preferably R-8.

By combining these elements of good practice, duct energy losses can be reduced to a maximum of 20% of the underlying heating and cooling loads, and better results can often be achieved. Adhering to these principles should also provide health, safety, and comfort levels nearly as good as those obtained with conditioned-space ductwork.

In contrast, a *run-of-the-mill* duct system laid out *on the fly* with little or no design calculations and

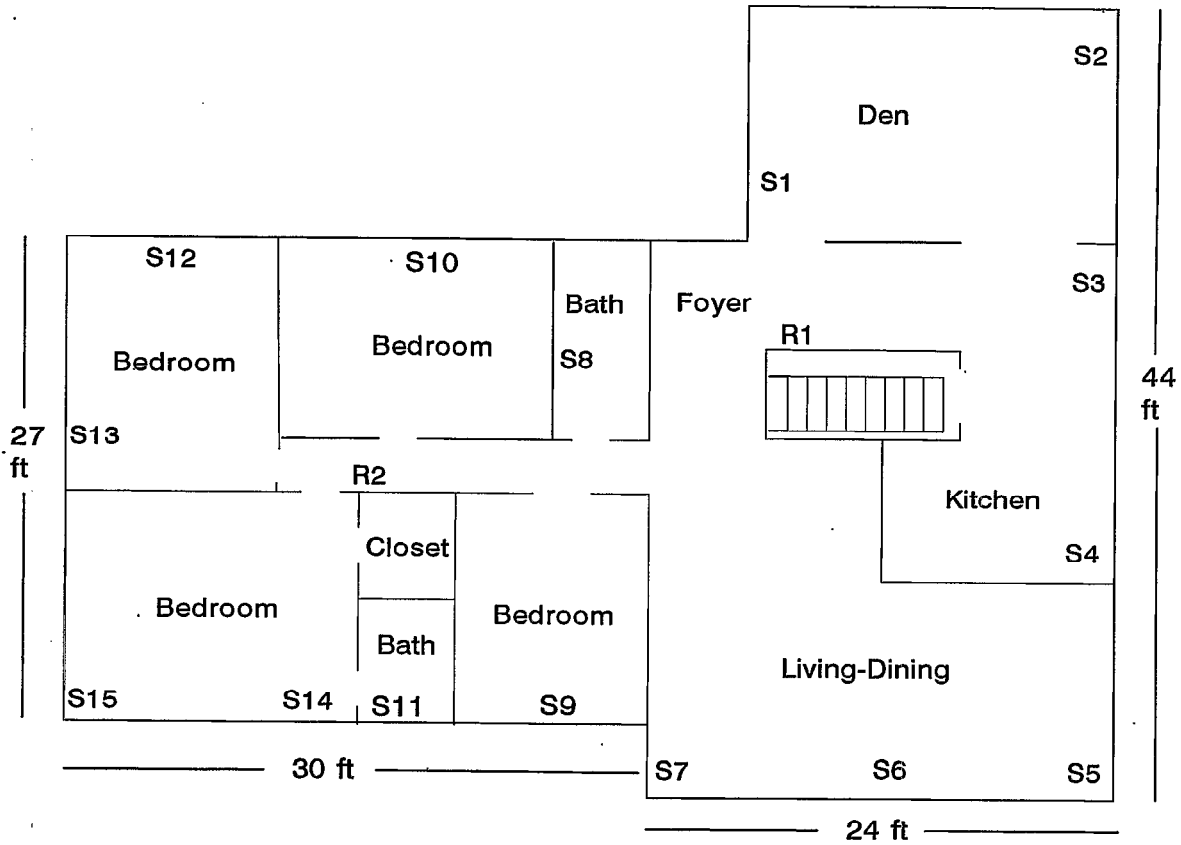

Figure 6 Example House Plan Single-story Ranch

minimal attention to air sealing will typically have energy losses approximating 33% to 67% of the underlying loads. Moreover, as discussed in Volume 2, it may lead to poor thermal comfort and unacceptable indoor air quality. To focus the discussion, let us consider a specific house plan (Figure 6), a single-story ranch-type house having a conditioned floor area of 1800 ft². With four bedrooms and a spacious den, it is representative of good middle-class American housing such as one might find in any region of the country. It could be built over a basement or crawl space (with the ducts underneath the house) or on a slab (with the ducts perhaps in the slab but more commonly in the attic). What the homeowner sees of the duct system are the fifteen supply registers (labeled S1-S15) and the two return registers (labeled R1 and R2). The rest of the system is *out of sight and out of mind*. We will use this house plan to illustrate energy-efficient duct layout options, setting the stage for duct design and thermal distribution efficiency calculations in Volume 4.

- **Typical Duct Construction Methods Today**

A duct layout that might result from a typical installation according to recent practice (neither especially good nor especially bad) is shown in Figure 7, with the room divisions shown as dotted lines. (This is based on an actual house constructed during the 1980's.) The ducts could be located in an attic, basement or crawl space. For the purpose of this example, we will use the crawlspace

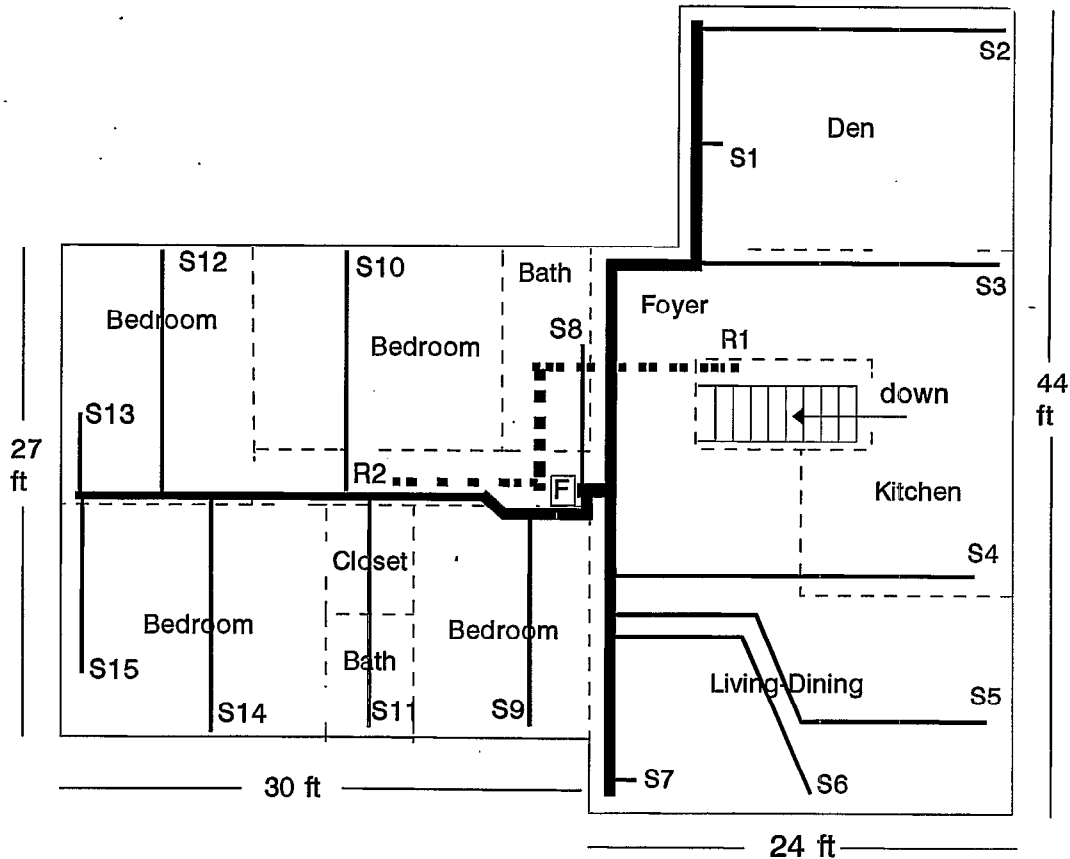

Figure 7 Duct Layout With Typical Installation In Example Ranch House

location. Starting at the furnace/air-conditioner (marked F in the diagram), a short main trunk duct leads to the right from the bonnet to a tee. This tee connects to a lateral trunk duct that serves the den, the foyer, the kitchen, and the living-dining area. A second trunk duct splits off from the short main trunk and heads to the left to serve the bedrooms and bathrooms. These trunks are all of rectangular sheet metal, insulated with R-4 duct wrap. Individual runouts of round sheet metal with R-4 insulation lead to each supply register. These registers are located adjacent to exterior walls, beneath the windows. The 15 supply registers, S1 through S15, are located in the floor.

The two return registers, R1 and R2, are located in the walls of the hallway and foyer, respectively. The return system, shown as heavy dotted lines, comprises a panned joist leading from R1 to a large central trunk and a freestanding duct leading from R2 to the same central trunk, which is connected to a vertical duct leading down to the return plenum of the upflow furnace.

The open plan of the daytime living area (on the right in Figure 7) allows for free air flow from the supply to the return registers, and register placement appears to provide good air circulation. However, the bedroom and bathroom doors, when closed, will severely limit return air flow from these rooms. This will likely degrade the system's energy efficiency, and it may also contribute to some of the health, safety, and comfort problems discussed in Volume 2.

The system has strengths and weaknesses. On the plus side, it is soundly constructed and is reasonably well laid out. Also, the ducts are insulated. The system has several defects, however. First, panned joists were employed to some extent; these are not recommended. Second, a higher R-value should have been chosen for the insulation. Third, as mentioned above, there was no provision for air flow from the bedrooms to the return ducts when the doors are closed. The final and most severe defect is that the measured duct leakage was between 15% and 20% of the system fan flow on both the supply and return sides.

- **Ducts in the Conditioned Space**

Placing ductwork in the conditioned space is an idea whose time has come. As with most such ideas, however, progress in the field often begins slowly. The example discussed here is intended to show how ductwork might be located in the heated and cooled zone. It is not claimed that this is the only way to do this. Many approaches to conditioned-space ducting are expected in the coming years. The ideas discussed here should apply to most, if not all, of them.

Figure 8 shows the same house plan as the previous two figures, but now instead of a duct system wending its way through the crawl space, we have a long trunk duct extending the full length of the conditioned space. In the bedroom hallway, it runs along the wall-ceiling interface. It then crosses the ceiling of the living-dining and kitchen areas as a boxed-in *summer beam* that could evoke the large support beams used in colonial post-and-beam construction. All of the existing register locations except S5 can be served by runouts extending along the room dividers or the end walls of the house. Figure 9 shows a view from the living-dining area toward the main entry foyer.

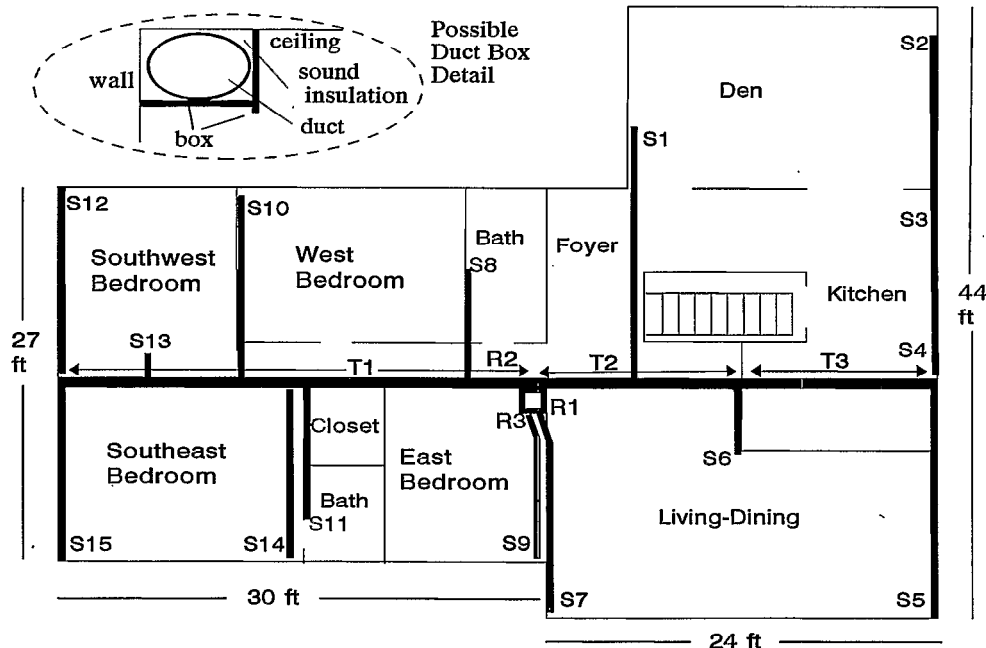

Figure 8 Example House With Ducts In Conditioned Space

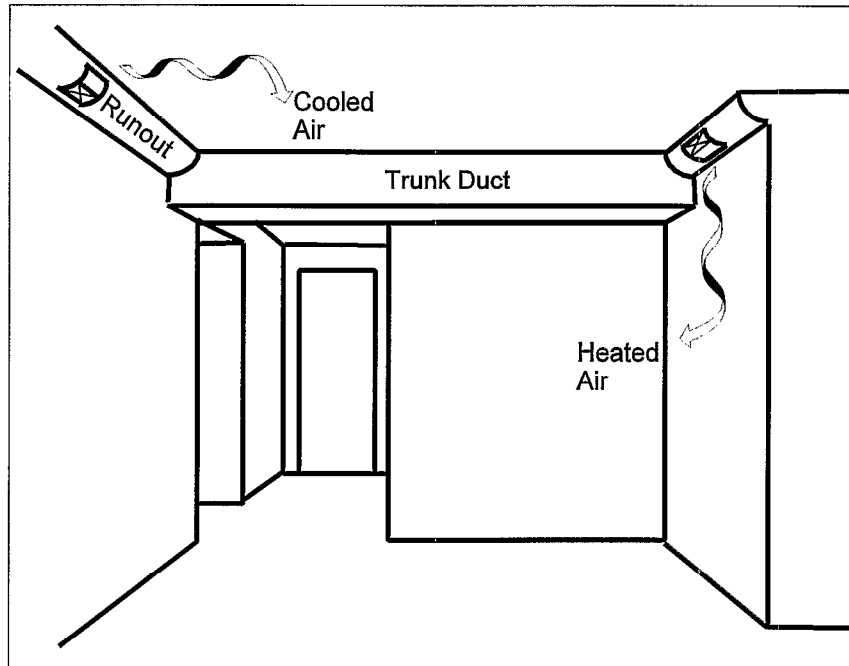

Figure 9
Duct In The Conditioned Space - View From The Living-Dining Towards Entry Foyer Of The Example House

In the actual house, these registers are located near the floor, whereas in the suggested plan they would be located near the ceiling. It's important to note, however, that with ceiling-level supply ducts it is important to select register diffusers with sufficient *throw* to inject air all the way to the floor to avoid stagnation in the heating mode. ASHRAE recommends that with high supply registers the return registers should be located low, near the floor, as the best compromise for year-round heating and cooling. [ASHRAE 1996 Systems and Equipment Handbook, p. 9.4] This is good advice, but it is important to remember that the location of the return registers has much less impact on air circulation than do the location and design of the supply registers.

Transfer ducts or grilles could lead from the front bedrooms to the hallway, or direct return linkages could be provided with somewhat greater detailing effort. It may be advisable not to do the same with the bathrooms, to avoid mixing offensive odors in the return air.

To keep the return system within the conditioned space, the registers R1 and R2 were moved closer to the furnace. R1 is located on the living-dining area wall adjacent to the east bedroom, and R2 is moved up the hallway so that its ductwork can be buried in the east bedroom closet, without having to negotiate the doorway. A small return R3 is added to serve this bedroom.

As for the furnace, the best plan from an energy standpoint would be to carve out space in the east bedroom for a heating and cooling equipment room. This would insure that all the ductwork is within the conditioned space, and it would also keep the ducts from being exposed to outside

conditions. In hot, humid climates such as Florida and the Gulf coast, locating ductwork in a vented crawl space is not a good idea, because cold air conditioning ducts will sweat (unless insulated far more than is usual). When combined with salt air, this can be a recipe for rapid corrosion and failure. Locating the equipment in the garage can give rise to health and safety problems, as discussed in Volume 2 of this series.

If the builder does choose to locate the heating equipment outside the conditioned space, it is important to remember that the pressures in ducts are greatest near the air handler, so it is essential that these ducts be well sealed and tested. Also make sure that they are sufficiently well insulated to prevent “sweating” under the most severe summertime conditions. If it is necessary to locate the equipment in the garage, the return ducts must be tightly sealed and a warning sign should be permanently displayed in a prominent and visible location on the equipment or a duct.

In any event, the return registers should be sized large enough so that the air velocity through them is less than 300 feet per minute, to minimize noise and perceptible drafts. By keeping the ducts in the conditioned space, the design heating and cooling loads will be reduced significantly, reducing the design cfm and allowing the return grille face area to be kept within reasonable bounds.

- **Good-Practice Conventional Duct System**

As noted above, good practice combines the elements of design, optimal routing, air sealing, and insulation. In addition to ensuring adequate air flow to every room, good design can minimize the effective length of a duct system, thereby reducing its required cross section. Careful consideration of routing options can minimize the physical length of the ducts. In other words, a duct design procedure using a recognized guidebook such as ACCA Manual D, when carried out on a well-laid-out duct plan, can minimize total duct surface area outside the conditioned space. This, when combined with adequate insulation, can greatly reduce conductive heat losses. Such a duct system, when carefully sealed, can almost always achieve or exceed the benchmark goal of a duct system that loses no more than 20% of the underlying heating and cooling loads.

SUMMARY OF GOOD PRACTICE

The following checklist reviews the important elements of good practice.

1. Calculate the loads. Don't guess. (Use ACCA Manual J.)
2. Size equipment properly. (Use ACCA Manual S.)
3. Keep ducts in the conditioned space as much as possible.
4. Use the ACCA Manual D duct sizing procedure.
5. Route ducts directly, especially if they have to be placed in unconditioned spaces.
6. Use low-loss duct fittings; this permits smaller duct cross sections to be used. (Duct fitting choices are covered extensively in ACCA Manual D.)
7. Locate registers near inside walls where feasible.
8. Seal ducts using a method that will ensure long life, i.e., U.L. Listed mastic.

9. Insulate ducts in unconditioned spaces (R-8 preferred).
10. Specify maximum 5% supply and return leakage to unconditioned spaces and require a test.

Detailed design examples for conditioned-space ducts and a good-practice conventional duct system are carried out in the next volume in this series (Volume 4, Designing for Energy-Efficient Ducts).

DUCT DESIGN STRATEGIES

Volume 4

**Better Duct Systems
for
Home Heating and Cooling**

Revision: July 2000

DUCT DESIGN STRATEGIES

This is the fourth in a series of guides intended to provide a working knowledge of residential duct systems, an understanding of the major issues concerning efficiency, comfort, health, and safety, and practical tips on installation and repair of duct systems. These guides are intended for use by contractors, system designers, advanced technicians, and other Heating Ventilating and Air-Conditioning (HVAC) professionals.

The purpose of Volume 4 is to provide detailed sizing calculations for the two recommended duct design strategies introduced in Volume 3. For the convenience of the reader, the descriptions of these strategies as given in that volume are repeated here.

RECOMMENDED DUCT DESIGN STRATEGIES

This section provides essential information on two approaches to better duct efficiency that were recommended in Volume 3:

1. Ducts in the conditioned space
2. Good-practice conventional duct systems.

Placing the ducts in the conditioned space is the most efficient choice. Duct energy losses can be eliminated if unintended leakage paths to the outside are carefully avoided. Even better, with ducts in the conditioned space, the health, safety, and comfort problems discussed in Volume 2 are unlikely to arise. Despite this, at least four impediments stand in the way of widespread use of conditioned-space ductwork:

1. Difficulty of hiding ductwork;
2. Perceived extra cost;
3. Need for the building designer to get involved with the details of duct design;
4. The scheduling of trades on the job is likely to be somewhat different.

Whenever these difficulties prevent the placement of ducts in the conditioned space, the next best choice should be considered. This is to reduce duct energy losses to a practical minimum through good practice. Good practice has the following elements:

Design the total heating and cooling system using a reliable method such as that embodied in the Air Conditioning Contractors of America (ACCA) Manuals J, S, and D.

Minimize the surface area of ducts outside the conditioned space through good routing, use of low-loss fittings, and (where feasible) placement of registers near interior walls.

Specify suitably low levels of air leakage to/from the outside and include a post-installation leakage test in the construction plan. As a benchmark, it is suggested that air leakage to/from the outside should not exceed 5% of total air flow on either the supply or return side.

Insulate ducts outside the conditioned space, at least to R-6 and preferably R-8.

By combining these elements of good practice, duct energy losses can be reduced to a maximum of 20% of the underlying heating and cooling loads, and better results can often be achieved. Adhering to these principles should also provide health, safety, and comfort levels nearly as good as those obtained with conditioned-space ductwork.

Volume 3 introduced a specific house plan (Figure 1), a single-story ranch-type house having a conditioned floor area of 1800 ft². The conventionally designed duct system had 15 supply registers (labeled S1 - S15) and two return registers (R1 and R2). The house could be built over a basement or crawl space (with the ducts underneath the house) or on a slab (with the ducts perhaps in the slab but more commonly in the attic). Regardless of foundation type, the ducts could also be located in the conditioned space. That is the preferred option. It is now widely recognized within the homebuilding industry that conditioned-space ductwork has many advantages that will repay builders' efforts to overcome the impediments acknowledged above.

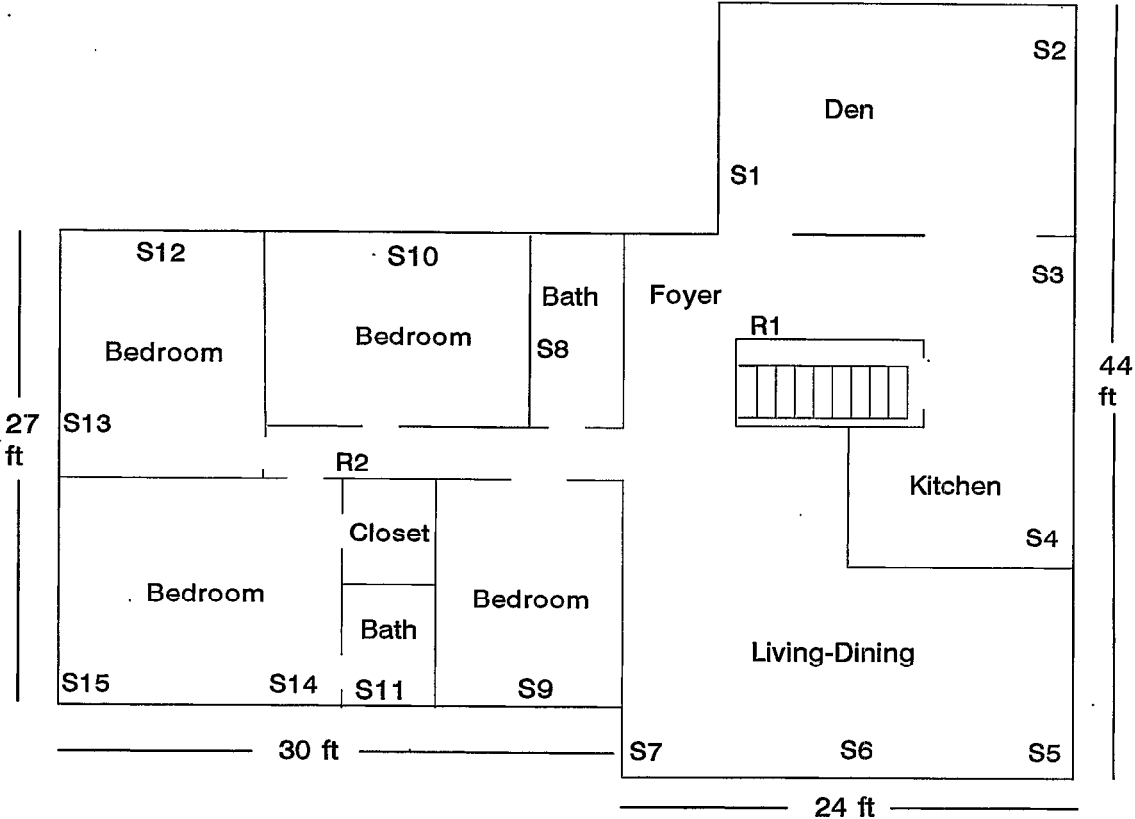

Figure 1 Example House Plan Single-story Ranch

- **Ducts in the Conditioned Space**

Placing ductwork in the conditioned space is an idea whose time has come. As with most such ideas, however, progress in the field often begins slowly. The example discussed here is intended to show how ductwork might be located in the heated and cooled zone. It is not claimed that this is the only, or even the best, way to do this. Many approaches to conditioned-space ducting are expected in the coming years. The ideas discussed here should apply to most if not all of them.

Figure 2 shows a duct layout for the house plan of Figure 1 that is compatible with placement inside the living space. It features a long trunk duct extending the full length of the house. In the bedroom hallway, it runs along the wall-ceiling interface. It then crosses the ceiling of the living-dining and kitchen areas as a boxed-in *summer beam* that could evoke the large support beams used in colonial post-and-beam construction. All of the existing register locations except S5 can be served by runouts extending along the room dividers or the end walls of the house. Figure 3 shows a view from the living-dining area toward the main entry foyer.

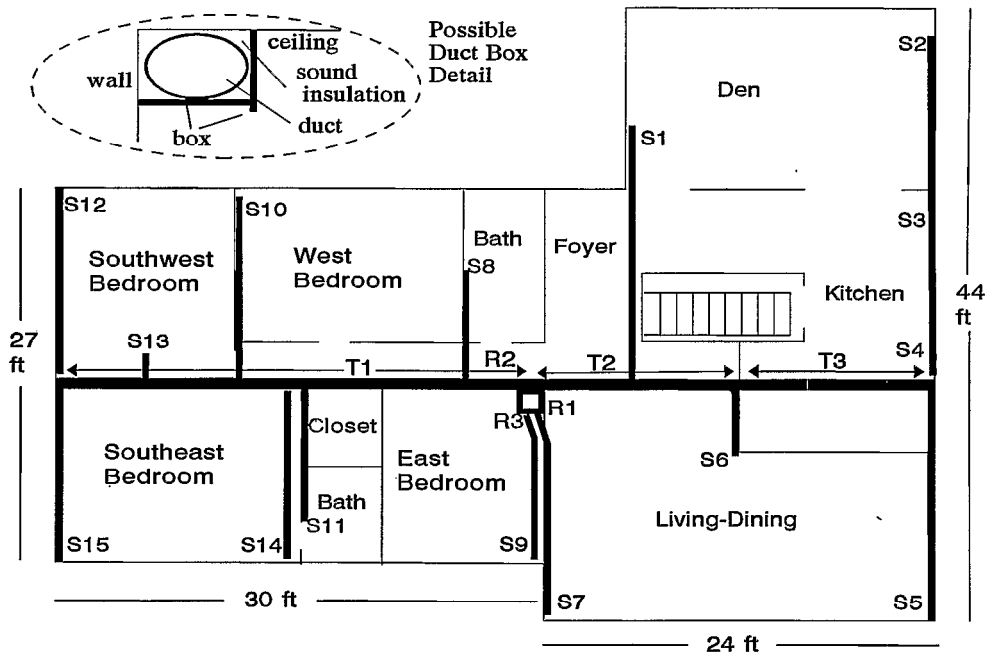

Figure 2 Example House With Ducts In Conditioned Space

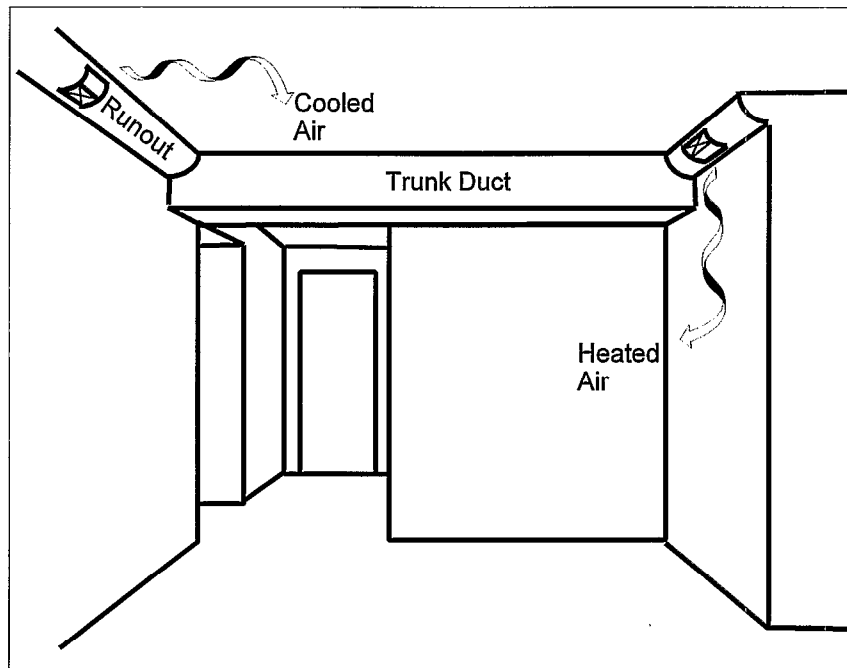

Figure 3
Duct In The Conditioned Space - View From The Living-Dining Towards Entry Foyer Of The Example House

A design detail that must not be overlooked is that in the suggested plan the supply registers are most easily located near the ceiling. It's important to note, however, that with ceiling-level supply ducts it is important to select register diffusers with sufficient *throw* to inject air all the way to the floor to avoid stagnation in the heating mode. ASHRAE recommends that with high supply registers the return registers should be located low, near the floor, as the best compromise for year-round heating and cooling.[ASHRAE 1996 Systems and Equipment Handbook, p. 9.4] This is good advice, but it is important to remember that the location of the return registers has much less impact on air circulation than do the location and design of the supply registers.

Transfer ducts or grilles could lead from the front bedrooms to the hallway, or direct return linkages could be provided with somewhat greater detailing effort. It may be advisable not to do the same with the bathrooms, to avoid mixing offensive odors in the return air.

To keep the return system within the conditioned space, the registers R1 and R2 were moved closer to the furnace. R1 is located on the living-dining area wall adjacent to the east bedroom, and R2 is

moved up the hallway so that its ductwork can be buried in the east bedroom closet, without having to negotiate the doorway. A small return R3 is added to serve this bedroom.

As for the furnace, space could be carved out of the east bedroom for a mechanical room, but the builder might prefer not to dedicate this much space to a utility that could be placed elsewhere. An alternative is to locate the furnace beneath the house. Admittedly, this is not within the conditioned space, but the amount of ductwork outside the heated and cooled zone will be small enough that efforts to seal these thoroughly should not be unduly difficult.

In any event, the return registers should be sized large enough so that the air velocity through them is less than 300 feet per minute, to minimize noise and perceptible drafts. By keeping the ducts in the conditioned space, the design heating and cooling loads will be reduced significantly, reducing the design cfm and allowing the return grille face area to be kept within reasonable bounds.

- **Good-Practice Conventional Duct System**

As noted above, good practice combines the elements of design, optimal routing, air sealing, and insulation. In addition to ensuring adequate air flow to every room, good design can minimize the effective length of a duct system, thereby reducing its required cross section. Careful consideration of routing options can minimize the physical length of the ducts. In other words, a duct design procedure using a recognized guidebook such as ACCA Manual D, when carried out on a well-laid-out duct plan, can minimize total duct surface area outside the conditioned space. This, when combined with adequate insulation, can greatly reduce conductive heat losses. Such a duct system, when carefully sealed, can almost always achieve or exceed the benchmark goal of a duct system that loses no more than 20% of the underlying heating and cooling loads. The following checklist reviews the important elements of good practice:

1. Calculate the loads. Don't guess. (Use ACCA Manual J.)
2. Size equipment properly. (Use ACCA Manual S.)
3. Keep ducts in the conditioned space as much as possible.
4. Use the ACCA Manual D duct sizing procedure.
5. Route ducts directly, especially if they have to be placed in unconditioned spaces.
6. Use low-loss duct fittings; this permits smaller duct cross sections to be used. (Duct fitting choices are covered extensively in ACCA Manual D.)
7. Locate registers near inside walls where feasible.
8. Insulate ducts in unconditioned spaces (R-8 preferred).
9. Specify maximum 5% supply and return leakage to unconditioned spaces and require a test.

COMPARISON OF DUCT SYSTEM DESIGNS

The design process begins with a load calculation using ACCA Manual J. For ease of comparison, the climate for our example is the same as the one used in Manual J's own examples (Cedar Rapids, Iowa). The thermal integrity of the house envelope is selected to be consistent with modern energy standards, but it is not an extreme or **super-insulated** house. Equipment performance parameters are consistent with the requirements of Manual S. Manual D is employed to size the ducts. The distribution efficiencies of the resulting systems are then compared using ASHRAE Standard 152. The body of this section summarizes the Manual J, S, and D calculations and the Standard 152 results. More detail is given in the Appendix.

Manual J Loads

Table 1 gives some characteristics of the climate, the house, and the components of the heating and cooling loads as derived from Manual J.

Table 1. Heating and Cooling Design Parameters and Manual J Loads

Parameter	Heating	Cooling
Outdoor design temperatures	-5 °F	90 °F db, 75 °F wb
Conditioned floor area	1800 ft ²	
Window and glass door area	272 ft ² (double pane)	
Foundation	vented crawl space	
Insulation level	R-19 wall, R-19 floor, R-30 ceiling	
Infiltration air changes per hour	0.55	0.30
Btu/h load, windows and glass doors	12 430	7 970
Btu/h load, opaque walls and doors	5 960	1 460
Btu/h load, ceiling	4 450	2 310
Btu/h load, floor	6 940	1 420
Btu/h load, infiltration	10 860	1 180
Btu/h load, people and appliances	N/A	3 000
Sum of sensible loads excluding ducts, Btu/h	40 640	17 340
Latent load, Btu/h (cooling only)	N/A	3 240

Missing from Table 1 is a calculation of duct losses (gains in cooling). Manual J has Duct Loss (Gain) Multipliers for heating (cooling) that are based on the location of the duct system and the degree to which it is insulated. However, these multipliers assume little or no duct leakage and are under revision. We will therefore use an alternative approach. We have outlined three basic duct design strategies: 1) put the ducts in the conditioned space; 2) use conventional duct placement but strive to minimize losses through surface area minimization, air sealing, and insulation; and 3) let nature take its course and hope for the best. (Needless to say, Strategy 3 is not recommended.) To each of these strategies, a Tentative Duct Loss/Gain Multiplier (TDM) is assigned*, as follows:

- Strategy 1 (Conditioned Space Ducts): TDM = 0.00
- Strategy 2 (Good Conventional Design): TDM = 0.20
- Strategy 3 (Typical Current Practice): TDM = 0.50

The intent of these benchmarks is to provide reasonably accurate values of heating and cooling loads for use in the equipment sizing and duct design processes. Hopefully, the distribution efficiencies as finally computed using ASHRAE Standard 152 should be sufficiently close to the benchmark values that the equipment will not need to be resized.

Table 2 summarizes the design heating and cooling loads under each of the above strategies. Note that we have adjusted both the sensible and the latent components of the cooling load to account for possible latent gains via return duct leakage and/or increased infiltration rates caused by air handler operation.

Table 2. Design Heating and Cooling Loads for Three Duct Design Strategies

Duct Design Strategy Btu/h Load	1. Ducts in Conditioned Space	2. Good Conventional Design	3. Typical Current Practice
Heating	40 640	48 770	60 960
Cooling (Sensible)	17 350	20 820	26 020
Cooling (Latent)	3 240	3 890	4 860
Cooling (Total)	20 590	24 710	30 880

*These TDM's correspond to distribution efficiencies of 100%, 83%, and 67%, respectively. For example, the typical current practice TDM of 0.50 means that the duct system loses 50% of the underlying envelope load. The equipment must supply 150% of this load, so the distribution efficiency is 100/150 or 67%.

Equipment Selection (Manual S)

In these examples, it will be assumed that an electric-powered air conditioner is to be mated to a gas furnace. This choice is made here because it is a common application and to simplify the example. It should not be construed as an endorsement of this type of equipment as opposed to any other, or of this energy-source combination, as opposed to any other.

This having been said, the relevant sections of Manual S are Section 3 (Air Conditioners) and Section 2 (Furnaces and Boilers). In Section 3, the input-output temperature difference on the indoor air-conditioning coil is determined to be 19 °F on the basis of an indoor relative humidity of 55% and a sensible heat ratio of 0.84. The air conditioner is sized to deliver sensible and latent outputs as close to the loads as possible. In an actual case, it would be necessary to secure manufacturer's data for units with approximately the right outputs and home in on the final characteristics using the procedures of Steps 3 and 4 of Section 3-10 in Manual S. Here we will assume that a unit has been found that provides sensible and latent cooling outputs reasonably close to the desired values shown in Table 2. The blower CFM values that result from the design process will then be as shown in the first row of Table 3.

The furnace is selected by choosing an output between 100% and 140% of the heating load. Although in practice a wide range of furnace sizes and efficiencies might be considered, for simplicity the examples given in Table 2-2 of Manual S were used. These happened to provide outputs within the guidelines for the three duct design strategies being considered here. The temperature-rise values (assuming that the same fan speed is used for heating as for cooling) are consistent with the manufacturer's limits quoted in Manual S, Table 2-2.

Table 3. Equipment Characteristics Resulting from Manual S Procedures

Duct Design Strategy	1. Ducts in Conditioned Space	2. Good Conventional Design	3. Typical Current Practice
Required system CFM, determined from cooling loads in Table 2	910	1100	1370
Output of selected heating furnace (Btu/h)	47 000	62 000	78 000
Temperature rise in furnace (°F)	47	51	52

Duct Design (Manual D)

The duct sizing procedure is described in Chapter 8 of Manual D. The Appendix (below) follows the Manual D procedure for the system with ducts in the conditioned space. A similar layout, transposed to the crawlspace, is used as the basis for a discussion of good conventional design.

The first step is to select the fan and determine the available static pressure which can be used by the duct system to drive air flow. This is done in Section 8-3 of Manual D. Section 8-4 takes the designer's proposed layout and determines the total effective lengths of the longest supply and the longest return branch. Effective length is a method that converts the flow resistance of fittings to a length of straight duct that would provide equal resistance to air flow. The ducts can then be sized as if they were a long, straight run. Section 8-5 obtains a design friction rate, which is a critical parameter that is not only useful for the sizing calculations but also can be used to assess whether a more-powerful or less-powerful fan should be considered. The next two sections determine the air flows needed by each room and the cfm to be assigned to each supply branch runout. Section 8-8 extends the air flow calculations to the trunks. Return flow rates are dealt with in the following two sections. Finally, Sections 8-11 and 8-12 get to the "meat" of the issue--duct sizing. How big do the ducts have to be?

In our example, we find that the duct sizes are small enough that the trunks could easily be run high along one wall of the bedrooms and across the dining room and kitchen ceilings as a boxed-in **summer beam**, pleasing aesthetically as well as functional mechanically. As for the branches, the air flow in a 6 inch round duct could be handled by a 5 inch by 6 inch cornice perhaps made out of a relatively thin plastic, sections of which might snap together and have a user-friendly means of attachment to the wall. They could either be left **as is** or, in **high-end** housing, spray-coated with a layer of plaster-like material that would merge them with the underlying sheet-rock. This would greatly reduce the cost of placing ducts in the conditioned space. It is hoped that such fittings will rapidly come to market once the benefits of efficient duct systems are more widely recognized.

Distribution Efficiency

The concept of distribution efficiency is basic to ASHRAE Standard 152. It is discussed in detail in Volume 5 of this series. For now, all we need to know is that distribution efficiency, to the extent that it is less than 100%, tells how much additional energy is required to heat or cool the house, over and above what would be needed by the same house, with the same equipment, but with a **perfect** duct system. For example, if the distribution efficiency is 70%, this means that for every 100 units of fuel or electrical energy needed to support heating or cooling in the actual house, only 70 units would be required if the ducts were **perfect**--no leaks, no conductive losses, and no system impacts.

Distribution efficiency comes in four **flavors**. These are defined on the basis of whether the mode is heating or cooling and whether the conditions are design (peak-load) or seasonal average. The ASHRAE Standard 152 spreadsheet was used to calculate distribution efficiencies for our example house, in the mid-western climate used for the Manual J load calculations.

The **typical current practice** was modeled by simply using the default values for duct leakage and surface area in Standard 152. These represent the best knowledge we have of how ducts in the real world typically perform today. The seasonal distribution efficiencies for heating and cooling for such a duct system are displayed in the first row of Table 4. The poor performance, especially in heating, is caused by the high leakage rates (17% of fan flow) that are typical of today's systems, combined with the inadequate R-4 insulation that is also typical.

The heating efficiency is worse than that for cooling because the average temperature difference across the duct surface is greater in the heating mode, and because the return leakage hurts more in the heating mode in a cold climate such as Iowa's. In Florida the numbers will be reversed.

In Strategy 2, distribution efficiency depends critically on the insulation level and the degree to which leakage to the outside can be contained. Table 4 shows some representative values using air leakage rates of 5% of system fan flow on both the supply and return sides and insulation R-values of 4 and 8. It should be emphasized that even the poorer set of numbers represents a duct system that is better than the average one being installed today. However, because going from R-4 to R-8 improves the distribution efficiency so much, it appears reasonable to use the higher insulation value. Going to R-12, however, only added one or two more percentage points, so for this system, at least, it appears we've found the **knee in the curve** on insulation. Reducing the leakage rates below 5% would improve distribution efficiency even more. When it comes to leakage, there is no **knee**, and the only limit is the practical difficulty of stopping up those last few percentage points of leakage.

Moral: When the decision is made not to put ducts in the conditioned space, it is critically important to seal and insulate well beyond what is typical in current practice.

Table 4. Distribution Efficiencies for Example Cases

Duct Leakage (% of Fan Flow)		Duct Insulation R-Value		Seasonal Distribution Efficiency (%)		Comments
Supply	Return	Supply	Return	Heating	Cooling	
17	17	4	4	56	75	Strategy 3. Poor performance, especially in the heating mode.
5	5	4	4	72	87	Strategy 2 with R-4 insulation. R-8 is better! (See next line.)
5	5	8	8	80	90	Suggested minimum standard for Strategy 2
1	2	8	8	94	98	Strategy 1. Note that the low leakage values are easier to
to achieve here than in Strategy 2, because most of the ductwork is inside the living space.						

For Strategy 1, we allowed the builder to put the equipment in the crawl space. This of course meant that a small amount of ductwork also had to be outside the conditioned zone. On the supply side, only 7% of the ductwork is outside the conditioned space, so we projected leakage to the outside at 7% of the Standard 152 default value, which is 17% of the system fan flow. Seven percent of 17% is 1%--so we'd expect the supply-side leakage to the outside to be about 1% of fan flow. Our example system has twice as much return duct surface area outside the living space as it does on the supply side, so return leakage (from outside) was benchmarked at 2% of fan flow. This should be a conservative assumption, because a builder who takes the trouble to put most of the ducts in the conditioned space will probably also want to seal effectively the small portion of the system that is exposed to unconditioned zones of the house.

Under these assumptions, and again using R-8 insulation on the small part of the duct system that is in the crawl space, the seasonal distribution efficiencies were 94% in heating and 98% in cooling. These values are displayed in the last row of entries in Table 4. Of course, if the equipment and all the ducts are in the living space and there is no leakage to the outside, these numbers will go up to 100%, but we wanted to illustrate the kind of tradeoff a builder might face if he decided to depart somewhat from the ideal. The lesson here is that **ducts in the conditioned space** is not an all-or-nothing concept. **Getting most of the ductwork into the conditioned space makes it that much easier to attend to the portions of the system that still remain outside.**

APPENDIX. DUCT DESIGN AND EFFICIENCY EXAMPLE

This appendix shows some of the calculations and intermediate steps involved in the use of ACCA Manuals J, S, and D on the example systems discussed above.

Details of Manual J Calculations

Table A-1 summarizes the parameters needed for the Manual J load calculation. These include relevant temperatures and Heat Transfer Multipliers. The climate location is Cedar Rapids, Iowa.

Table A-1. Assumed Design Conditions and Construction

Parameter	Table (Man. J)	Units	Heating	Cooling
Outside Design Temperature (°F)	1	°F	-5	90
Grains Difference @ 55% RH	1		N/A	38
Inside Dry Bulb Temperature (°F)		°F	70	75
Design Temperature Difference (°F)		°F	75	15
Window 3B: Clear fixed glass, dbl pane	2	HTM	45.7	N/A
Window 8N: Sliding glass door, dbl pane	2	HTM	45.7	N/A
Window, north facing	3a	HTM	N/A	14
Window, east or west facing	3a	HTM	N/A	44
Window, south facing	3a	HTM	N/A	23
Door 11E: Metal, urethane core, no storm	2,4	HTM	14.3	3.5
Wall 12H: 6" stud 24" o.c., R-19	2,4	HTM	4.5	1.1
Ceiling 16G: Basic, vented attic, R-30	2,4	HTM	2.5	1.3
Floor 20D: Over vented crawlspace, R-19	2,4	HTM	3.5	0.8
Infiltration (see note below)	5	HTM	37.2	4.1

Calculation of the heat transfer multipliers (HTMs) for infiltration heating and sensible cooling loads is shown in Figure A-1 at the end of this appendix (Form J-1 from ACCA Manual J) under Procedure A and Procedure B. Assumptions made are as follows:

10. Conditioned volume (1800 ft² floor area X 8 ft ceiling) = 14 400 ft³.
11. Winter air change assumed midway between **average** and **best** or 0.55 ACH
12. Summer air change assumed midway between **average** and **best** or 0.30 ACH

Figure A-1 also shows the calculation of the infiltration latent load according to Procedure C and, for Strategy 1, the equipment sizing loads according to Procedure D. For Strategies 2 and 3, these loads are increased by 20% and 50%, respectively. We have assumed a moderately tight envelope with no forced ventilation.

Tables A-2a, A-2b, and A-2c show Manual J load calculations for the three duct design strategies: ducts in conditioned space, good-practice conventional duct system, and typical current practice, respectively.

The calculations of loads using the Manual J procedures are shown on a room-by-room basis in the spreadsheet Tables A-2a, A-2b, and A-2c. These tables are for Strategies 1, 2, and 3, respectively, reflecting the tentative duct loss/gain multipliers of 0.00, 0.20, and 0.50 as explained in the main text of this volume. The resulting heating and cooling loads are summarized in Table 2, which is repeated here as Table A-3 for convenience:

Table A-3. Design Heating and Cooling Loads for Three Duct Design Strategies (Same as Table 2)

Duct Design Strategy Btu/h Load	1. Ducts in Conditioned Space	2. Good Conventional Design	3. Typical Current Practice
Heating	40 640	48 770	60 960
Cooling (Sensible)	17 350	20 820	26 020
Cooling (Latent)	3 240	3 890	4 860
Cooling (Total)	20 590	24 710	30 880

Details of Manual S Calculations

Sizing the Air Conditioner

Air conditioner sizing is done according to Section 3-10 of Manual S. Table A-3 summarizes the sensible and latent loads, and Table A-4 gives the cooling fan flow rates resulting from the calculations from this procedure, for each of the three strategies..

Step 1--Produce a Set of Design Parameters

Climate--Cedar Rapids, Iowa

Outdoor dry-bulb temperature--90 F

Indoor dry-bulb temperature--75 F

Indoor wet-bulb temperature--64 F

Sensible load and latent loads from Procudre D of Manual J, as shown in Table A-3.

Table A-2a. Manual J Load Calculations for Strategy 1, Ducts in Conditioned Space

1 Name of Room		DUCTS IN CONDITIONED SPACE															
2 Running ft Exposed Wall		Entire House 192															
3 Room Dimensions ft		53 X 44															
4 Ceiling Ht. Ft.		8															
Directions Room Faces		1 Den				2 Kitchen				3 Living/Dining							
		13 X 19				20 X 11				12 X 24							
		8 North/West/South				8 North				8 North/East/South							
TYPE OF EXPOSURE		Cons. No.		HTM		Area or Length		Btuh		Area or Length		Btuh		Area or Length		Btuh	
		Htg		Clg.		Htg		Clg.		Htg		Clg.		Htg		Clg.	
5	Gross Exposed Walls & Partitions	a	12h			1536				352				160			
		b				0											
		c				0											
		d				0											
6	Windows & Glass Doors	a	3b	45.7		230	10511			52	2376			24	1097		
		b	8h	45.7		42	1919				0			42	1919		
		c				0	0				0				0		
		d				0	0				0				0		
7	Windows & Glass Doors	North				14	94			14	1316			196	65		
		E&W				44	122			22	968						
		South				23	56			16	1288						
		Clg.				0	0			0	0			0	0		
8	Other Doors	11a	14	3	3.5	20	286			0	0			0	0		
9	Net Exposed Walls & Partitions	a	12h	4.5	1.1	1262	5679	1388		300	1350	330		94	423	103	
		b				0	0			0	0			0	0		
		c				0	0			0	0			0	0		
		d				0	0			0	0			0	0		
10	Ceiling	a	16g	2.5	1.3	1779	4448	2313		247	618	321		250	625	325	
		b				0	0			0	0			0	0		
11	Floors	a	20d	3.9	0.9	1779	6938	1423		247	963	198		250	975	200	
		b				0	0			0	0			0	0		
12	Infiltration HTM					37.2	4.05			52	1934			66	2455		
13	Sub Total Btuh Loss = 6 + 8 + 9 + 10 + 11 + 12										7242				7494		
14	Duct Btuh Loss = 0 % or edist					1.000					0				0		
15	Total Btuh Loss = 13 + 14										7242				7494		
16	People @ 300 & Appliances 1200										3000				1200		
17	Sensible Btuh Gain = 7 + 8 + 9 + 10 + 11 + 12 + 16										17349				3020		
18	Duct Btuh Gain = 0 % or edist					1.000					0				0		
19	Total Sensible Gain = 17 + 18										17349				3020		

4 W. Bath		5 E. Bedroom		6 W. Bedroom		7 E. Bath		8 SW Bedroom		9 SE Bedroom	
5 X 11		10 X 15		11 X 14		4 X 11		11 X 14		15 X 15	
8 West		8 East		8 West		8 East		8 SouthWest		8 East/South	
Area or Length		Area or Length		Area or Length		Area or Length		Area or Length		Area or Length	
Htg		Htg		Htg		Htg		Htg		Htg	
Btuh		Btuh		Btuh		Btuh		Btuh		Btuh	
Clg.		Clg.		Clg.		Clg.		Clg.		Clg.	
40		80		112		32		200		240	
6	274	12	548	17	777	5	229	30	1371	36	1645
	0		0		0		0		0		0
	0		0		0		0		0		0
	0		0		0		0		0		0
6	264	12	528	17	748	5	220	13	572	18	792
	0		0		0		0		0		0
	0		0		0		0		0		0
	0		0		0		0		0		0
32	144	35	308	75	428	105	27	122	30	170	765
	0		0		0		0		0		0
	0		0		0		0		0		0
	0		0		0		0		0		0
55	138	72	375	195	154	385	200	44	110	57	154
	0		0		0		0		0		0
	0		0		0		0		0		0
55	215	44	150	585	120	154	601	123	35	154	601
	0		0		0		0		0		0
	0		0		0		0		0		0
6	223	24	12	445	49	17	632	69	5	186	20
	993		2261		2822		818		30	1115	122
	0		0		0		0				4238
	993		2261		2822		818				4238
	439		966		1245		362				1595
	0		0		0		0				0
	439		966		1245		362				1595

Table A-2b. Manual J Load Calculations for Strategy 2, Good Practice Conventional Duct

1 Name of Room		GOOD PRACTICE CONVENTIONAL DUCTS						Entire House			1 Den			2 Kitchen			3 Living/Dining				
2 Running ft Exposed Wall								192			44			20			40				
3 Room Dimensions ft								53 X 44			13 X 19			20 X 11			12 X 24				
4 Ceiling Ht. Ft.		Directions Room Faces						8			8 North/West/South			8 North			8 North/East/South				
TYPE OF EXPOSURE		Cons. No.		HtM		Area or Length		Bluh		Area or Length		Bluh		Area or Length		Bluh		Area or Length		Bluh	
		Htg.		Clg		Htg.		Clg		Htg.		Clg		Htg.		Clg		Htg.		Clg	
5	Gross Exposed Walls & Partitions	a	12h			1536				352				160				320			
		b				0															
		c				0															
		d				0															
6	Windows & Glass	a	3b	45.7		230	10511			52	2376			24	1097			48	2194		
		b	8h	45.7		42	1919				0			42	1919				0		
		c				0	0				0				0				0		
		d				0	0				0				0				0		
7	Windows & Glass		North			14	94			14	1316			66	196			14	196		
			E&W			44	122			22	5368				968			29	1276		
			South			23	56			16	1288				368			5	115		
			Clg			0	0			0	0				0			0	0		
8	Other Doors		11a	14.3		3.5	20	286		0	0			0	0			20	286		70
9	Net Exposed Walls & Partitions	a	12h	4.5	1.1	1262	5678	1388	300	1350	330	94	423	103	272	1224	299				
		b				0	0	0	0	0	0			0	0	0	0				
		c				0	0	0	0	0	0			0	0	0	0				
		d				0	0	0	0	0	0			0	0	0	0				
10	Ceilings	a	16g	2.5	1.3	1779	4448	2313	247	618	321	250	625	325	500	1250	650				
		b				0	0	0	0	0	0			0	0	0	0				
11	Floors	a	20d	3.9	0.8	1779	6938	1423	247	963	198	250	975	200	500	1950	400				
		b				0	0	0	0	0	0			0	0	0	0				
12	Infiltration HTM			37.2	4.05	292	10862	1183	52	1934	211	66	2455	267	68	2530	275				
13	Sub Total Bluh Loss = 6 + 8 + 9 + 10 + 11 + 12						40643			7242			7494			9433					
14	Duct Bluh Loss = 20% or edist 0.833						8129			1448			1499			1887					
15	Total Bluh Loss = 13 + 14						48772			8690			8993			11320					
16	People @ 300 & Appliances 1200							3000		500			1200			900					
17	Sensible Bluh Gain = 7 + 8 + 9 + 10 + 11 + 12 + 16						17349			3491			3020			4182					
18	Duct Bluh Gain = 20% or edist 0.833						3470			698			604			836					
19	Total Sensible Gain = 17 + 18						20819			4190			3624			5018					

4 W Bath		5 E Bedroom		6 W. Bedroom		7 E. Bath		8 SW Bedroom		9 SE Bedroom	
5 X 11		10 X 15		11 X 14		4 X 11		11 X 14		15 X 15	
8 West		8 East		8 West		8 East		8 South/West		8 East/South	
Area or Length	Bluh	Area or Length	Bluh	Area or Length	Bluh	Area or Length	Bluh	Area or Length	Bluh	Area or Length	Bluh
Htg.	Clg	Htg.	Clg	Htg.	Clg	Htg.	Clg	Htg.	Clg	Htg.	Clg
40		60		112		32		200		240	
6	274	12	548	17	777	5	229	30	1371	38	1645
	0		0		0		0		0		0
	0		0		0		0		0		0
	0		0		0		0		0		0
8	264	12	528	17	748	5	220	13	572	18	792
	0		0		0		0	17	391	18	414
	0		0		0		0		0		0
	0		0		0		0		0		0
32	144	35	306	75	95	428	105	27	122	30	170
	0		0		0		0		0		0
	0		0		0		0		0		0
	0		0		0		0		0		0
55	138	72	375	193	154	385	200	44	110	57	154
	0		0		0		0		0		0
	0		0		0		0		0		0
	0		0		0		0		0		0
53	215	44	585	120	154	601	123	44	172	35	154
	0		0		0		0		0		0
	0		0		0		0		0		0
	0		0		0		0		0		0
6	223	24	445	49	17	632	89	5	188	20	30
	993		2261			2822	818		4238		5342
	199		452			564	164		848		1066
	1192		2713			3387	981		5085		6411
	439		966			1245	362		1595		2049
	88		193			249	72		319		410
	527		1160			1494	435		1914		2458

Table A-2c. Manual J Load Calculations for Strategy 3, Typical Current Practice

1 Name of Room		TYPICAL CURRENT PRACTICE			Entire House			1 Den			2 Kitchen			3 Living/Dining		
2 Running ft Exposed Wall					192			44			20			40		
3 Room Dimensions ft					53 X 44			13 X 19			20 X 11			12 X 24		
4 Ceiling Ht. Ft.		Directions Room Faces			8			8 North/West/South			8 North			8 North/East/South		
TYPE OF EXPOSURE		Conc. No.	Htg.	HTM Clg.	Area or Length	Htg.	Btuh Clg.	Area or Length	Htg.	Btuh Clg.	Area or Length	Htg.	Btuh Clg.	Area or Length	Htg.	Btuh Clg.
5	Gross Exposed Walls & Partitions	12n			1536			352			160			320		
6	Windows & Glass Doors Htg.	3b, 8n	45.7		230, 42	10511, 1919		52, 42	2376, 1919		24, 42	1097, 1919		48, 0	2184, 0	
7	Windows & Glass Doors Clg.	North, E&W, South			14, 44, 23	94, 122, 56		1316, 5368, 1288	14, 22, 18		196, 968, 368	66, 0, 0		924, 0, 5	14, 29, 115	196, 1276, 115
8	Other Doors	11e	14.3	3.5	20	286	70	0	0	0	0	0	0	20	286	70
9	Net Exposed Walls & Partitions	12n	4.5	1.1	1262	5679	1388	300	1350	330	94	423	103	272	1224	299
10	Ceatings	16g	2.5	1.3	1779	4448	2313	247	618	321	250	625	328	500	1250	650
11	Floors	20d	3.9	0.8	1779	6938	1423	247	963	198	250	975	200	500	1950	400
12	Infiltration HTM		37.2	4.05	292	10852	1183	52	1834	211	66	2455	267	68	2530	275
13	Sub Total Btuh Loss = 5 + 6 + 9 + 10 + 11 + 12				40643			7242			7484			8433		
14	Duct Btuh Loss = 50% or edist				20322			3621			3747			4717		
15	Total Btuh Loss = 13 + 14				60965			10862			11242			14150		
16	People @ 300 & Appliances 1200				3000			900			1200			900		
17	Sensible Btuh Gain = 7 + 8 + 9 + 10 + 11 + 12 + 16				17349			3481			3020			4182		
18	Duct Btuh Gain = 50% or edist				8674			1745			1510			2091		
19	Total Sensible Gain = 17 + 18				26023			5227			4530			6272		

4 W. Bath		5 E. Bedroom		6 W Bedroom		7 E. Bath		8 SW Bedroom		9 SE Bedroom	
5 X 11		10 X 15		11 X 14		4 X 11		11 X 14		15 X 15	
8 West		8 East		8 West		8 East		8 South/West		8 East/South	
Area or Length	Htg.	Area or Length	Htg.	Area or Length	Htg.	Area or Length	Htg.	Area or Length	Htg.	Area or Length	Htg.
40		80		112		32		200		240	
6	274	12	548	17	777	5	229	30	1371	36	1645
0	0	0	0	0	0	0	0	0	0	0	0
0	0	0	0	0	0	0	0	0	0	0	0
6	264	12	528	17	748	5	220	13	572	18	782
0	0	0	0	0	0	0	0	17	361	18	414
0	0	0	0	0	0	0	0	0	0	0	0
0	0	0	0	0	0	0	0	0	0	0	0
32	144	35	308	75	95	428	105	27	122	30	170
0	0	0	0	0	0	0	0	0	0	0	0
0	0	0	0	0	0	0	0	0	0	0	0
0	0	0	0	0	0	0	0	0	0	0	0
55	136	72	150	375	195	154	385	200	44	110	57
0	0	0	0	0	0	0	0	0	0	0	0
55	216	44	150	585	120	154	601	123	44	172	35
0	0	0	0	0	0	0	0	0	0	0	0
0	0	0	0	0	0	0	0	0	0	0	0
6	223	24	448	49	17	632	69	5	188	20	30
863		2261		2822		818		4236		5342	
497		1130		1411		409		2119		2671	
1490		3391		4234		1228		6356		8014	
439		956		1245		362		1583		2049	
220		483		622		181		797		1024	
659		1450		1867		544		2382		3073	

Step 2--Estimate the Cooling CFM

Sensible Heat Ratio = (Sensible load)/(Sensible+latent loads)=0.84 for all 3 strategies.

Leaving Air Temperature = 56 F

Temperature Difference = 75 - 56 = 19 F

Cooling CFM = Sensible load/(1.1 X Temperature difference)

Table A-4. Cooling Fan Flow Rates

	Strategy 1	Strategy 2	Strategy 3
Cooling fan flow rate CFM	910	1100	1370

Steps 3 and 4--For the purposes of this example, it is assumed that a cooling package has been selected that will produce the baseline cooling CFM's as determined above and meet the Manual J loads.

Sizing the Furnace

It is assumed that the procedures of Section 2 (Manual S) have been carried out to identify a specific furnace with a capacity that falls between the design heating load and 1.4 times the design heating load. The example furnaces shown in Table 2-2 of Manual S are used as candidates. The sensible loads are taken from Procedure D, Manual J. The furnace and blower choices that match the heating load window (1.0 - 1.4 times the design load) and the fan cfm determined from the air conditioner sizing are given in Table A-5.

Table A-5. Furnace and Blower Selection

	Strategy 1	Strategy 2	Strategy 3
Heating load (Btu/h)	40640	48770	60970
1.4 times the heating load (Btu/h)	56900	68280	85360
Furnace selected from Table 2-2 in Manual S (output in Btu/h)	H-60 47 000	H-80 62 000	H-100 78 000
Blower selection for external resistance 0.3 - 0.5 IWC	H-80	H-80	HC-80
Temperature rise (F)	47	51	52

Details of Manual D Calculations

The calculations required by Manual D are described in Chapter 8 of that manual. These are summarized here.

Section 8-3 of Manual D--Available Static Pressure

Step 1-- Fan static pressure. Static pressure delivered by the selected fan at the required CFM is determined in this step. We will use the H-80 and HC-80 blower performance tables (2-3 and 2-4) in manual S (Section 2-2) to do this. (This assumes the same blowers are provided in H-60, H-80, and H-100 furnaces, which might not be true, but which is assumed for the purpose of this example.) For Strategy 1, the required CFM is 910. The med-low setting of the H-80 blower will provide 910 CFM at an external resistance of 0.38 IWC (inches of water column). No other setting will provide this flow rate at any static pressure between 0.2 and 0.6 IWC, so we are left with the choice of accepting this or looking for another unit.

For Strategy 2, the required CFM is 1100. The med-high setting of the H-80 blower is the only one that can deliver this flow rate at a static pressure between 0.2 and 0.6 IWC. Interpolating in the table, one finds an external resistance corresponding to this CFM of 0.51 IWC. For Strategy 3, where 1370 CFM is required, the med-high setting of the HC-80 blower (Table 2-4) will correspond to 0.60 IWC.

Step 2--Pressure losses from air-side components. Here it is assumed that the only air-side components to consider are the cooling coil, the filter, return grilles, balancing dampers, and supply air outlets. Coil and filter resistance must be determined from manufacturer's data. If the blower is provided with the air conditioner or with a heat pump, the data usually is given with the coil already in place, and so nothing needs to be subtracted for it. Similarly, the data should say whether the filter is included in the blower performance data. Here, since we are using a blower that is packaged in a furnace, it is reasonable to expect that the filter is included, but the cooling coil is not. We will use the cooling coil resistance data given in Table 8-2 of Manual D for convenience. This would mean that for Strategy 1 (910 CFM) the coil resistance is 0.07 IWC, for Strategy 2 (1100 CFM) it is 0.11 IWC, and for Strategy 3 (1370 CFM) it is 0.17 IWC. In line with Manual D's suggestion, we subtract 0.03 IWC for each of three items: return grille, balancing damper, and supply outlet.

Step 3--Available Static Pressure. The available static pressures (ASP) for each strategy are:

- Strategy 1: $0.38 - 0.07 - 0.03 - 0.03 - 0.03 = 0.22$ IWC
- Strategy 2: $0.51 - 0.11 - 0.03 - 0.03 - 0.03 = 0.31$ IWC
- Strategy 3: $0.60 - 0.17 - 0.03 - 0.03 - 0.03 = 0.34$ IWC.

Section 8-4 of Manual D--Effective Length Design Value

The next step computes the effective length (EL) of each branch of the duct system on the supply and return side. Hence, it is necessary that there be a detailed duct layout at this point. For the sake of clarity, *we will concentrate on Strategy 1*. The duct system for Strategy 2 will be considered as a minor modification of the one developed here. The Strategy 3 duct system will be taken to be the one actually installed in a house very similar to the one in our example.

Strategy 1. In Strategy 1, we want to minimize the size of any duct in the conditioned space (to make it easy to integrate into the interior structure). Therefore, the equipment was placed in a central location, directly beneath the point (nearest the hallway) where the lower right hand (see Figure 3) bedroom abuts the living-dining area. This allows about half the air into each half of a double-trunk system. Also, air can go directly to registers S-7 and S-9 without passing through a trunk at all.

On the supply side, coming out of the furnace we'll need 10 feet of riser (8 ft in the living space and 2 feet under the house) coupled with effective lengths for the double flow bend first from vertical to horizontal and then splitting into the north and south halves of the main trunk. If turning vanes are used in these fittings, it should be possible to keep the total effective length (TEL) of the run from the furnace into the trunk duct to 60 feet (10 feet for the riser and 20-25 feet each for a radius bend with vanes and a vaned tee (Groups 8-C and 1-P in Manual D's Appendix 3). Branch takeoffs are taken from Group 2E if the fitting is not at the end of a trunk duct, and from Group 9L if it is. These are chosen to give reasonably low values of EL. Finally it is assumed that trunk T1 serving the bedroom area is of constant dimension while the trunk serving the living areas contracts on going into the kitchen, so the stretch across the living-dining area is called T2 and the stretch in the kitchen is T3, with a transition between the two costing 5 feet of EL (Group 12-D). The column labeled **register inlet** allows 40 feet of effective length for the configuration of vanes or other devices needed to provide adequate **throw** for the ceiling-level registers proposed for Strategy 1. Table A-6 summarizes the EL's for the flow paths from the furnace to the various registers. Figures A-2a and A-2-b at the end of this appendix show the same data entered into the ACCA Manual D Residential Duct Sizing Calculations forms.

The returns are set up with one main return (R1) facing the living-dining area and the other (R2) facing the hallway. A smaller return (R3) takes air directly from the lower right hand bedroom; the other bedrooms are to be served by transfer grilles that admit air flow into the hallway. The den, foyer, kitchen, and living-dining areas are open-plan, with air flow pathways to the return-register area. The bathrooms are not provided with returns. It is assumed that when they are not in use the doors will be open (the usual practice in the U.S., though not in some other countries) and when they are in use an exhaust fan will be in operation. Table A-7 shows the EL's on the return side.

The largest supply-side TEL is 187 feet, while the largest return TEL is 139 feet, giving a system TEL equal to 326 feet.

Table A-6. Effective Lengths for Supply Runs (Strategy 1)

Supply Run	Furnace to trunk	Trunk	Branch takeoff	Run-out	Boot	Total EL
1	60	5 (T2)	25(2E)	20	40	144
2	60	13(T2) 5(12-D) 11(T3)	20(9L)	27	40	170
3	60	13(T2) 5(12-D) 11(T3)	20(9L)	11	40	154
4	60	13(T2) 5(12-D) 11(T3)	20(9L)	4	40	147
5	60	13(T2) 5(12-D) 11(T3)	20(9L)	17	40	160
6	60	13(T2)	30(2E)	6	40	143
7	60	none	70(2L)	17	40	181
8	60	5(T1)	50(2E)	10	40	159
9	60	none	70(2L)	13	40	177
10	60	19(T1)	50(2E)	14	40	177
11	60	15(T1)	50(2E)	10	40	169
12	60	30(T1)	20(9L)	14	40	158
13	60	25(T1)	45(2E)	2	40	166
14	60	15(T1)	50(2E)	13	40	172
15	60	30(T1)	20(9L)	13	40	157

Table A-7. Effective Lengths for Returns (Strategy 1)

Return Run	Plenum	Riser	Junction Fitting	Branch Fitting	Run out	Boot	Total EL
1	30(5H)	12	75(10A)	10(6B)	0	10(6N)	137
2	30(5H)	12	75(10A)	10(6B)	2	10(6N)	139
3	30(5H)	12	75(10A)			10(6N)	127

Strategy 2. For strategy 2, we will assume that the supply duct system is placed beneath the house, in the crawl space, and that the registers are either in the floor or low on the walls. For simplicity, the return system will be assumed to be the same as in Strategy 1. The only modification to the effective length calculations, above, then, will be to deduct 8 feet from the supply effective

lengths on each run to reflect the fact that the riser from the furnace to the living-space ceiling is not required. The system TEL is then reduced to 318 feet.

Strategy 3. In this strategy the duct system was not designed according to the ACCA manuals, but installed by the contractor using past experience and rules of thumb as a guide. We will not go through a design process for this **strategy** either, but will use the actual duct system's characteristics in a later chapter when the system efficiencies are compared using the methods of ASHRAE Standard 152.

Section 8-5 of Manual D--Friction Rate Design Value

In this section the friction rate (FR) is calculated from the available static pressure (ASP), found using the methods of Section 8-3 of Manual D, and the system TEL, using

$$FR = (ASP \times 100)/TEL.$$

Strategy 1. For this strategy, the ASP was 0.22 IWC, which with the TEL of 326 feet leads to $FR = 0.068$. Consulting the chart in Figure 8-3 of Manual D shows that this FR is within the range of reasonable values (0.06 to 0.18) that should keep air flow velocities within acceptable limits. (However, this must be verified later on in the design process. See below.)

Strategy 2. Here, $ASP = 0.31$ IWC, which with the TEL of 318 feet leads to $FR = 0.098$. This is essentially equal to the 0.10 that is often taken as a "benchmark" value for this parameter.

The friction rate calculations are entered in the ACCA Manual D form as shown, at the end of this appendix, in Figure A-3a for Strategy 1 and A-3b for Strategy 2. (This form also summarizes the pressure loss calculations covered previously in this appendix.)

Section 8-6 of Manual D--Room CFM

Section 8-7 of Manual D--Branch Runout Air Flow Rates

The next step is to calculate the air flow needed by each room. This is a simple matter of apportioning the total CFM according to the fraction of the load in each room. A wrinkle in the procedure, however, is that the required flows may be different for heating and cooling. In this case, the higher of the two flows is to be used.

The Heating and Cooling room cfm values for Strategies 1 and 2, as entered in the ACCA Manual D form, are shown at the end of this appendix in Figure A-4a for Strategy 1 and A-4b for Strategy 2. For each strategy, under the Design heading, the larger of the two flows is entered, split where indicated into two (or in one case three) supply registers. There is no hard-and-fast rule about how many registers are needed, and indeed this house may have more than necessary. However, it was desired to show how the ducts could be moved into the conditioned space with no loss of comfort, relative to the system that actually was installed in this house.

Section 8-8 of Manual D--Supply Trunk Flow Rates

This section of Manual D calculates the flow rates in each section of trunk duct.

Strategy 1. Using the procedures described there, which basically involve adding the flows from all runouts leading from the trunk section and from any trunk section downstream of the one under consideration, one obtains a flow of 340 cfm in Trunk 3 (S2, S3, S4, and S5); 490 cfm in Trunk 2 (S1, S6, and Trunk 3); and 325 cfm in Trunk 1 (S8 and S10 through S15). Registers S7 and S9, with 130 cfm, are to be served directly from the supply plenum/riser and so do not figure in the trunk flows. This information is entered in the Supply Trunk rows of Figure A-4a, at the end of this appendix.

Strategy 2. The flow in Trunk 3 in this strategy is 405 cfm. The Trunk 2 flow is now 590 cfm, while the Trunk 1 flow rate becomes 395 cfm. (See Figure A-4b.)

Section 8-9 of Manual D--Return Branch Flow Rates

These are calculated under the assumption that return R1 is to handle flows from the living area ; R2 handles flows from the bedroom area (except for the East Bedroom); and R3 handles the lower right hand bedroom.

Strategy 1. In this strategy, R1 should be designed for 570 cfm; R2 for 325 cfm, and R3 for 50 cfm. Because of the open nature of the plan and the proximity of registers R1 and R2, some tradeoff between these flows should be acceptable.

Strategy 2. Here, R1 should handle 685 cfm and R2 should take 395 cfm. R3 is again responsible just for the lower right hand bedroom, which now requires 60 cfm. These total 1140 cfm.

Section 8-10 of Manual D--Return Trunk Flow Rates

Since there is only one return trunk in this design, it will need to carry the whole design air flow, or 945 cfm in Strategy 1 and 1140 cfm in Strategy 2.

Section 8-11 of Manual D--Branch Sizing

Strategy 1. Using the FR of 0.068 found in Section 8-5 together with the friction chart in Appendix 2 of Manual D (or a duct slide rule), we obtain the sizes of round duct needed for the branches as shown in the seventh column of Figure A-4a. The velocities resulting from these flows and diameters (column 8) are all well within the guidelines of Manual D's Chapter 3 (Table 3-1), which recommend a 600 fpm maximum for branch ducts.

Strategy 2. Here the FR was 0.098. Using this value with the larger air flow rates demanded by Strategy 2 results in the same branch diameters as in Strategy 1. (See Figure A-4b.) The air flow velocities are somewhat higher. They are still all below the 600 fpm recommended maximum, however. This brings to light an important point. We could have searched around for a somewhat more powerful fan to use in Strategy 1. With its higher FR, the duct diameters in Strategy 1 might have been reduced somewhat. The amount of such reduction is limited, within the velocity guidelines. Ducts especially designed for higher velocities might be used with a yet more powerful fan, and this could make considerably smaller runout sizes feasible.

Section 8-12 of Manual D--Trunk Sizing

This section will size the three sections of supply trunk, the supply riser, and the return downcomer.

Strategy 1. Again using the flow rates for each trunk section and $FR = 0.068$ in Chart 1 of Manual D's Appendix 1, one obtains the round sizes shown under Strategy 1 in the Supply Trunk area of Figure A-4a. It is also necessary to check the velocity, to make sure that it is within the guidelines shown in Table 3-1 on page 3-6 of Manual D. The supply trunks and riser are within the recommended 700 fpm guidelines.

The return duct **runs** R1 and R2 are really just short connections into the return downcomer. To satisfy the criterion of 500 fpm maximum return-grille face velocity, the equivalent round sizes should be increased to 14.5 inch and 11 inch, respectively. These translate to the rectangular sizes shown in the return-trunk rows of Figure A-4a.

Strategy 2. Here $FR = 0.098$. This value, together with the flow rates in the trunk sections, leads to the round sizes shown in Figure A-4b. The supply trunks are well within the maximum velocity limits but above the recommended ones, so the final sizes were increased somewhat. As in Strategy 1, the return registers were increased in size to meet the 500 fpm face-velocity guideline. The riser and downcomer in this strategy are quite short and would probably be constructed as simple plenums in any event, but should also be larger than indicated by the flow-loss calculation.

Section 8-13 of Manual D--Equivalent Rectangular Sizes

The conversion chart between round and rectangular ducts (Chart 9 of Manual D's Appendix 2) can be used to select a cross section consistent with the designer's aesthetic goals. Trunk 1, for example, could be embodied in a cornice with a 12 inch by 9 inch profile (allowing one inch for the thickness of the duct plus its casing, which might be gypsum or particle board). The largest branch is 6-inch round, which converts to a 6 inch by 5 inch rectangular duct, if rectangular runouts were to be used for conditioned-space ducts.

Figure A-1 Infiltration and Equipment Sizing Calculations (ACCA Manual D)

Calculation Procedures A,B,C,D

Procedure A - Winter Infiltration HTM Calculation (ALL STRATEGIES)

1. Winter Infiltration CFM	0.55 AC/HR x 14400 Cu. FT. x 0.0167 = 132 CFM
	Volume
2. Winter Infiltration Btuh	1.1 x 132 CFM x 75 Winter TD = 10900 Btuh
3. Winter Infiltration HTM	10900 Btuh ÷ 292 Total Window = 37.3 HTM
	& Door Area

Procedure B - Summer Infiltration HTM Calculation (ALL STRATEGIES)

1. Summer Infiltration CFM	0.30 AC/HR x 14400 Cu. FT. x 0.0167 = 72 CFM
	Volume
2. Summer Infiltration Btuh	1.1 x 72 CFM x 15 Summer TD = 1190 Btuh
3. Summer Infiltration HTM	1190 Btuh ÷ 292 Total Window = 4.08 HTM
	& Door Area

Procedure C - Latent Infiltration Gain (ALL STRATEGIES)

0.68 x 38 gr. diff. x 72 Summer CFM = 1860 Btuh

Procedure D - Equipment Sizing Loads (STRATEGY 1)

1. Sensible Sizing Load	
Sensible Ventilation Load	
1.1 x 0 Vent. CFM x 15 Summer TD	= 0 Btuh
Sensible Load for Structure (Line 19)	+ 17350 Btuh
Sum of Ventilation and Structure Loads	= 17350 Btuh
Rating & Temperature Swing Multiplier *	x 1.00 RSM
Equipment Sizing Load - Sensible	= 17350 Btuh
2. Latent Sizing Load	
Latent Ventilation Load	
0.68 x 0 Vent. CFM x 38 gr. diff.	= 0 Btuh
Internal Loads = 230 x 6 No. People	+ 1380 Btuh
Infiltration Load From Procedure C	+ 1860 Btuh
Equipment Sizing Load - Latent	= 3240 Btuh

* Refer to Table 6



Air Conditioning Contractors of America

Form J-1
Including Calculation Procedures A, B, C, D
© Copyright by the
Air Conditioning Contractors of America
1712 New Hampshire Avenue, NW
Washington, DC 20009

Printed in U.S.A.
1996

Figure A-2a Effective length Calculations (ACCA Manual D)



Air Conditioning Contractors of America

1712 New Hampshire Avenue, NW
 Washington, DC 20009
 (202) 483-9370 Fax (202) 234-4721

Date
Job Number
System Number of
Name
Phone
Address

Manual D Residential Duct Sizing Calculations

System Information					
Number of Zones	1	Number of Returns	3	Manual J Sensible Cooling Load	17350 BTUH
Type of System	Location		Manual J Heating Load	40640	BTUH
Supply-Side Materials ...	Trunk	Branch	Location of Duct Runs ...	Supply	Return
Return-Side Materials ...	Trunk	Branch	R-Value of Duct Wall ...	Supply	Return

Summary of Installed Equipment					
Type of Heating Device			Type of Cooling Equipment		
Make	Model		Make	Model	
Output BTUH	Auxiliary KW	(Heat Pump)	Nominal Cooling Capacity BTUH		

Effective Length Calculation Sheet									
Element	Supply Run ID Number				Element	Return Run ID Number			
	# 1	# 2	# 3	# 4		# 1	# 2	# 3	# 4
Trunk Length*	10	10	10	10	Trunk Length	12	12	12	
Trunk Length	5	13	13	13	Trunk Length				
Trunk Length		11	11	11	Trunk Length				
Runout Length	20	27	11	4	Runout Length		2		
Group 1 *	25	25	25	25	Group 5	30	30	30	
Group 2	25				Group 6	10,10	10,10	10	
Group 3					Group 7				
Group 4					Group 8				
Group 8 *	25	25	25	25	Group 10	75	75	75	
Group 9		20	20	20	Group 11				
Group 11					Group 12				
Group 12		5	5	5	Other				
Other (Register)	40	40	40	40	Other				
Other					Other				
Other					Other				
Total Length	150	176	160	153	Total Length	137	139	127	

*Riser and fittings, all supply runs
 These forms are published as a public service by the Air Conditioning Contractors of America.
 Copyright © 1995, Air Conditioning Contractors of America.

Figure A-2b Effective length Calculations, Continued (ACCA Manual)



Effective Length Calculation Sheet									
Element	Supply Run ID Number				Element	Return Run ID Number			
	# 5	# 6	# 7	# 8		#	#	#	#
Trunk Length*	10	10	10	10	Trunk Length				
Trunk Length	13	13		5	Trunk Length				
Trunk Length	11				Trunk Length				
Runout Length	17	6	17	10	Runout Length				
Group 1 *	25	25	25	25	Group 5				
Group 2		30	70	50	Group 6				
Group 3					Group 7				
Group 4					Group 8				
Group 8 *	25	25	25	25	Group 10				
Group 9	20				Group 11				
Group 11					Group 12				
Group 12	5				Group 13				
Group 13					Other				
Other (Register)	40	40	40	40	Other				
Other					Other				
Other					Other				
Total Length	166	149	187	165	Total Length				

Effective Length Calculation Sheet									
Element	Supply Run ID Number				Element	Supply Return Run ID Number			
	# 9	# 10	# 11	# 12		# 13	# 14	# 15	#
Trunk Length*	10	10	10	10	Trunk Length*	10	10	10	
Trunk Length		19	15	30	Trunk Length	25	15	30	
Trunk Length					Trunk Length				
Runout Length	13	14	10	14	Runout Length	2	13	13	
Group 1*	25	25	25	25	Group 1*	25	25	25	
Group 2	70	50	50		Group 2	45	50		
Group 3					Group 3				
Group 4					Group 4				
Group 8 *	25	25	25	25	Group 8 *	25	25	25	
Group 9				20	Group 9			20	
Group 11					Group 11				
Group 12					Other 12				
Other (Register)	40	40	40	40	Other (Register)	40	40	40	
Other					Other				
Other					Other				
Other					Other				
Total Length	183	183	175	164	Total Length				

*Riser and fittings, all supply runs.
 These forms are published as a public service by the Air Conditioning Contractors of America.
 Copyright © 1995, Air Conditioning Contractors of America.

Figure A-3a Friction Rate Worksheet for Strategy 1 (ACCA ManualD)

ACCA

Friction Rate Work Sheet	
Step 1) Manufacturer's Blower Data	
External static pressure (ESP) =	<u>0.38</u> IWC CFM = <u>910</u>
Step 2) Device Pressure Losses	
Direct expansion refrigerant coil	<u>0.07</u>
Electric resistance heating coil	_____
Hot water coil	_____
Heat exchanger	_____
Low efficiency filter	_____
High or mid efficiency filter	<u>INCLUDED</u>
Electronic filter	_____
Humidifier	<u>0.03</u>
Supply outlet	<u>0.03</u>
Return grille	<u>0.03</u>
Balancing damper	_____
Other device	_____
Total device losses (DPL)	<u>0.16</u> IWC
Step 3) Available Static Pressure	
ASP = (ESP - DPL) =	(<u>0.38</u> - <u>0.16</u>) = <u>0.22</u> IWC
Step 4) Total Effective Length (TEL)	
Supply-Side TEL + Return-Side TEL =	(<u>187</u> + <u>139</u>) = <u>326</u> FEET
Step 5) Friction Rate Design Value (FR)	
FR value from friction rate chart =	<u>0.068</u> IWC/100
<p style="text-align: center;">Friction Rate Chart</p> <p>The chart plots Total Effective Length (TEL) on the y-axis (0 to 500) against Available Static Pressure on the x-axis (0.05 to 0.4). Diagonal lines represent friction rates from 0.05 to 0.18. A point is plotted at approximately (0.22, 326). A box labeled 'Inadequate Fan Performance' points to the upper-left region, and another box labeled 'Fan is too Powerful' points to the lower-right region.</p>	

These forms are published as a public service by the Air Conditioning Contractors of America. Copyright © 1995, Air Conditioning Contractors of America.

Figure A-3b Friction Rate Worksheet for Strategy 2 (ACCA Manual D)

ACCA

Friction Rate Work Sheet	
Step 1) Manufacturer's Blower Data	
External static pressure (ESP) =	<u>0.51</u> IWC CFM = <u>1100</u>
Step 2) Device Pressure Losses	
Direct expansion refrigerant coil	<u>0.11</u>
Electric resistance heating coil	_____
Hot water coil	_____
Heat exchanger	_____
Low efficiency filter	<u>INCLUDED</u>
High or mid efficiency filter	_____
Electronic filter	_____
Humidifier	<u>0.03</u>
Supply outlet	<u>0.03</u>
Return grille	<u>0.03</u>
Balancing damper	_____
Other device	_____
Total device losses (DPL)	<u>0.20</u> IWC
Step 3) Available Static Pressure	
ASP = (ESP - DPL) =	<u>(0.51 - 0.20) = 0.31</u> IWC
Step 4) Total Effective Length (TEL)	
Supply-Side TEL + Return-Side TEL =	<u>(179 + 139) = 318</u> FEET
Step 5) Friction Rate Design Value (FR)	
FR value from friction rate chart =	<u>0.09⁰</u> IWC/100
<p style="text-align: center;">Friction Rate Chart</p> <p>The chart plots Total Effective Length (TEL) on the y-axis (0 to 500) against Available Static Pressure on the x-axis (0.05 to 0.4). Diagonal lines represent friction rates from 0.06 to 0.18 IWC/100. A point is plotted at approximately (0.31, 318), which falls between the 0.08 and 0.10 lines. Annotations include: 'Inadequate Fan Performance' (increase speed, change blower, reduce TEL) and 'Fan is too Powerful' (decrease speed, increase TEL, high runout velocity).</p>	

These forms are published as a public service by the Air Conditioning Contractors of America.
 Copyright © 1995, Air Conditioning Contractors of America.
 Figure A-3b Friction Rate Work Sheet for Strategy 2 (ACCA Manual D)

Figure A-4a Duct Sizing Worksheet for Strategy 1 (ACCA Manual D)

ACCA STRATEGY 1

Duct Sizing Worksheet								
HF = Blower CFM / Manual J Heat Loss = (910)(40640) = 0.0224								FR Value
CF = Blower CFM / Manual J Sensible Heat Gain = (910)(17350) = 0.0525								.068
Supply Duct System								
Run - Trunk	H-BTUH	C-BTUH	H-CFM	C-CFM	Dsn CFM	Round Size	Velocity	Final Size
1 - 2	7242	3491	162	183	90	6"	460	6"
2 - 3					90	6"	460	6"
3 - 3	7494	3020	168	159	85	5.9" (use 6")	430	6"
4 - 3					85	5.9" (use 6")	430	6"
5 - 3	9433	4182	211	220	80	5.8" (6")	410	6"
6 - 2					60	5.1" (5")	430	5"
7 - NONE					80	5.8" (6")	410	6"
8 - 1	993	439	22	23	25	3.8" (4")	290	4"
9 - NONE	2261	966	51	51	50	4.9" (5")	370	5"
10 - 1	2822	1245	63	65	65	5.3" (6")	330	6"
11 - 1	818	362	18	19	20	3.5" (4")	220	4"
12 - 1	4238	1595	95	84	50	4.9" (5")	370	5"
13 - 1					45	4.8" (5")	330	5"
14 - 1	5342	2049	120	108	60	5.1" (5")	430	5"
15 - 1					60	5.1" (5")	430	5"
					325	9.8" (10")	600	11" x 8"
					490	11.4" (12")	620	15" x 8"
					340	9.9" (10")	630	11" x 8"
					945	14.5" (16")	680	12" x 18"
Return Duct System								
Run - Trunk	Associated Supply Runs	H-CFM	C-CFM	Dsn CFM	Round Size	Velocity	Final Size	
1 - 1	1,2,3,4,5,6,7			570	12"	620	10" x 18"	
2 - 1	8,10,11,12,13,14,15			325	9.8" (10")	600	9" x 12"	
3 - 1	9			50	4.9" (5")	370	5"	
4 -								
5 -								
6 -								
7 -								
8 -								
9 -								
10 -								
11 -								
12 -								
				945	14.5" (16")	680	12" x 18"	

1) H-BTUH and C-BTUH from the Manual J room load calculation procedure.
 2) H-CFM = HF x H-BTUH and C-CFM = CF x C-BTUH
 3) Dsn CFM = larger of the H-CFM or C-CFM values (runout ducts) ... or ... total downstream CFM (trunk ducts).
 4) Round size based on FR value. Final size based on FR value (if the velocity is acceptable) or the maximum allowable velocity value.

These forms are published as a public service by the Air Conditioning Contractors of America.
 Copyright © 1995, Air Conditioning Contractors of America.

Figure A-4b Duct Sizing Worksheet for Strategy 2 (ACCA Manual D)

ACCA

STRATEGY 2

Duct Sizing Worksheet								
HF = Blower CFM / Manual J Heat Loss = (1100)(48770) = 0.0226								FR Value
CF = Blower CFM / Manual J Sensible Heat Gain = (1100)(20820) = 0.0528								.078
Supply Duct System								
Run - Trunk	H-BTUH	C-BTUH	H-CFM	C-CFM	Dsn CFM	Round Size	Velocity	Final Size
1 - 2	8690	4190	196	221	110	6"	550	6"
2 - 3					110	6"	550	6"
3 - 3	8993	3624	203	191	100	5.8"(use 6")	510	6"
4 - 3					100	5.8"(use 6")	510	6"
5 - 3	11320	5018	256	265	100	5.8"(6")	510	6"
6 - 2					65	5"	490	5"
7 - NONE					100	5.8"(6")	510	6"
8 - 1	1192	527	27	28	30	3.8"(4")	350	4"
9 - NONE	2713	1160	61	61	60	4.8"(5")	440	5"
10 - 1	3387	1494	77	79	80	5.4"(6")	410	6"
11 - 1	981	435	22	23	25	3.6"(4")	280	4"
12 - 1	5085	1914	115	101	60	4.8"(5")	440	5"
13 - 1					55	4.7"(5")	400	5"
14 - 1	6411	2458	145	130	65	5"	490	5"
15 - 1					80	5.4"(6")	410	6"
					395	9.8"(10")	790	14" X 8"
					590	11.5"(12")	760	16" X 10"
					405	9.9"(10")	800	14" X 8"
					1140	14.5"(16")	790	20" X 14"
Return Duct System								
Run - Trunk	Associated Supply Runs	H-CFM	C-CFM	Dsn CFM	Round Size	Velocity	Final Size	
1 - 1	1, 2, 3, 4, 5, 6, 7			685	12"	870	12" X 18"	
2 - 1	8, 10, 11, 12, 13, 14, 15			395	9.7"(10")	730	9" X 14"	
3 - 1	9			60	4.9"(5")	440	5"	
4 -								
5 -								
6 -								
7 -								
8 -								
9 -								
10 -								
11 -								
12 -								
				1140	14.5"(16")	790	14" X 20"	

1) H-BTUH and C-BTUH from the Manual J room load calculation procedure.
 2) H-CFM = HF x H-BTUH and C-CFM = CF x C-BTUH
 3) Dsn CFM = larger of the H-CFM or C-CFM values (runout ducts) . . . or . . . total downstream CFM (trunk ducts).
 4) Round size based on FR value. Final size based on FR value (if the velocity is acceptable) or the maximum allowable velocity value.

TESTING AND DIAGNOSING DUCT SYSTEMS

Volume 5

**Better Duct Systems
for
Home Heating and Cooling**

Rev: January 5, 2001

TESTING AND DIAGNOSING DUCT SYSTEMS

This is the fifth in a series of guides intended to provide a working knowledge of residential heating and cooling duct systems, an understanding of the major issues concerning efficiency, comfort, health, and safety, and practical tips on installation and repair of duct systems. These guides are for use by contractors, system designers, advanced technicians, and other heating, ventilating, and air-conditioning (HVAC) professionals.

This volume provides a step-by-step procedure to tell whether or not a duct system is performing well. Visual inspection can reveal some flaws, but many poorly performing systems look just fine. The need for quantitative testing must therefore be recognized, but with a practical view to the limited time that a builder or contractor can profitably spend on such detective work.

- **Step One—Inspect the Duct System**

Evaluating a duct system's efficiency begins with visual inspection. This means looking for telltale signs that a duct system needs repair. This can be done in the course of a general inspection of the home's heating system.

- **Step Two—Test for Duct Leakage**

The second step is to test for duct leakage. Air leakage from ducts is important not only because of its energy costs, but also because many of the comfort, health and safety problems that arise in duct systems are caused by air leakage.

- **Step Three—Measure the System Air Flow Rate**

It is nearly as important to measure the air flow rate at the system fan as it is to measure duct leakage. One reason for this is that the efficiency of the duct system depends not on duct leakage alone but on duct leakage as a fraction of fan flow. A second and equally important reason is that low fan flow is one of the major causes of poor air-conditioner performance. Whatever the problem that caused the original call for help, it will usually pay both the contractor and the customer if all problems besetting the system can be fixed in the same service call.

- **Step Four—Determine What Actions to Take**

Sometimes it will be obvious what needs to be done. Other times there will be a question of how much effort to put into duct repair. It will seldom pay to reduce duct energy losses all the way to zero. Three possible ways to make the decision are rules of thumb, program guidelines, and use of a standard to estimate the benefits of various corrective actions. An Internet web site <http://DUCTS.LBL.GOV/> is available that can provide guidance in estimating the efficiency impacts of various duct-repair options.

VISUAL INSPECTION

For the contractor, time is money. It is therefore essential that he have, at the top of his duct-repair toolkit, some quick methods of assessing whether any particular duct system is likely to need upgrading. This section discusses some things you can look for that don't need any special measuring equipment.

General Appearance. The quickest thing one can do to evaluate a duct system is . . . look at it! The first thing to note is the **general appearance** of the duct system. A good-looking system might or might not have unacceptable air leakage, but if a system is badly damaged in places or generally decrepit, it is almost certain to have problems. You may find that the system was installed properly but was damaged later on, either by the homeowner (by storing heavy items on top of ducts that are not designed to carry weight) or by other trades trying to get past the ducts on their way to a plumbing or electrical repair job. (This is especially likely--and understandable--where the various services to the house are installed close together in tight spaces.)

Even if the duct sections themselves are in good repair, they may be disconnected in places. Occasionally sections are left disconnected during the construction process. More often the joints become separated later on.

One building practice that is somewhat controversial is the use of the building itself as part of the duct system. Most common is the "panned joist," in which two joists and the overlying subfloor are used as three sides of a duct, with the fourth side made up from a flat piece of sheet metal nailed to the bottom edges of the joists. Although there is no reason why such a duct can't be made virtually airtight, in practice they seldom are. On the return side, use of closets and chases as pathways for air flow from the living space back to the heating/cooling equipment is even more likely to give rise to large amounts of air leakage.

Location. In addition to general appearance, the **location** of the duct system within the house is also important. Location means what kind of space the ducts are in--attic, crawl space, slab, basement, etc. Of all these possible locations, the one that is most prone to high energy losses is the attic, particularly in hot, humid climates. Studies in Florida and California have shown that peak cooling loads can easily double because of poorly performing attic ductwork. Leaky return ducts cause hot, moist attic air to be drawn into the system, placing an extra load on the air conditioner. Leaky and poorly insulated supply ducts lose chilled air and cause whatever cool air is left in the duct to be warmed up. Cases have been reported in which the air coming from the supply registers was actually warmer than the air in the house, because the air conditioner couldn't keep up with the duct losses!

A vented crawl space is a somewhat better location for ducts than an attic, because peak-load efficiency in the cooling mode tends to be higher. As in an attic, the ducts are in an environment that is similar to that outside the house, but at least they are not super-warmed by the hot summer sun during the peak cooling season.

Basements, even if not intentionally conditioned, are usually better locations for ducts than either attics or crawl spaces, because they are not exposed to the harshest outdoor temperatures. Also, some of the duct losses are effectively regained. Heat lost into a basement tends to warm it somewhat. This somewhat retards further heat conduction losses from the ducts, and it also reduces the rate of heat loss from the house through the basement ceiling. However, there is some evidence that ducts actually installed in basements tend to leak more than ducts installed in crawlspaces and attics, and basement ducts are more often left uninsulated.

One question that has to be considered before repairing basement ducts is the probability that the basement temperature will be lower in winter as a result. One study reported an average basement temperature drop of 5 °F as a result of duct retrofits. Make sure that this will not pose a problem for the homeowners in terms of their use of the space. If fear of freezing pipes is the issue, consider whether this can be addressed by insulating any vulnerable pipe runs.

The best location for ductwork is within the conditioned space. Any heat or cooling that leaks to the living space may be regarded as useful, and not lost at all, unless air leakage is so great that it becomes impossible to balance the system. Energy savings of up to 40% have been demonstrated by moving ductwork into the conditioned space.

People often ask whether a basement should be considered part of the conditioned space. If the basement is used for human activities and not just storage, and if there are registers in the basement, then it is part of the living space. In such cases the basement walls should be insulated. Duct insulation is needed only if required to keep the ducts from “sweating” in the cooling mode.

Equipment Replacement Opportunity. Besides the general appearance and location of the duct system, the third important factor that would influence a decision to look at the duct system is if **equipment replacement** is needed. Fixing leaky and poorly insulated ducts is especially critical if new heating or cooling equipment is to be installed, because the sizing of this equipment depends on the load, and the load can usually be greatly reduced through duct repairs. Savings in first cost available through equipment downsizing can help to pay for the cost of repairing the ducts. In some cases these savings may completely offset the duct-repair costs, shrinking the payback time to zero. This is one of the “golden opportunities” discussed in Volume 3 of this manual, but it bears repeating here.

Summary Checklist. The following situations represent opportunities to show the homeowner why his or her duct system’s efficiency and performance should be investigated further:

- The duct system is badly damaged in places or has the general appearance of being “on its last legs.”
- The duct runs themselves appear to be sound, but one or more disconnected sections are found.

- The system includes panned joists or other strategies employing the building itself as part of the ductwork.
- The house is in a hot, humid climate and the ducts are located in the attic.
- Regardless of climate, there are uninsulated ducts located outside the conditioned space.
- It has been determined that the heating or cooling equipment needs to be replaced.

If any of the above conditions is present, the house should be selected for further evaluation. Even if none of these conditions exists, serious duct leakage is nevertheless a strong possibility. Many homeowners, when informed about duct energy losses, health and safety issues, and comfort problems, will be interested in some further testing of their system even if there are no obvious telltale signs.

Once it has been decided to evaluate the efficiency of the duct system, the next step is to perform a leakage test. You can, of course, take measures to fix duct leaks without doing any testing. But testing is a good idea even if you are confident that the system leaks badly. Then you can show the homeowner what the extent of the leakage is. If you repeat the test after fixing the leaks, you can show the homeowner (and yourself!) how much good you did.

TESTING FOR DUCT LEAKAGE

The state of the art in duct leakage testing is in a rapid state of development. Currently there is a tradeoff between accuracy and ease of use. The test method described in this manual was selected to provide results as accurate as possible consistent with time and labor requirements that are low enough for contractors and builders to consider using it. If and when there is a significant advance in the state of the art in duct leakage testing that improves accuracy without increasing labor, or reduces labor without compromising accuracy, this manual will be updated. For up-to-date information on this and other points concerning duct efficiency, check the web site <http://DUCTS.LBL.GOV/> which is maintained by the Lawrence Berkeley National Laboratory.

Putting a number on duct leakage generally involves the measurement of two physical quantities:

- Static pressure. Pressure is the force exerted by air on each unit area of a surface. Static pressure is the value of the pressure after the effect of air movement has been factored out. Duct leakage is influenced by static pressure, so this is what we want to measure.
- Air flow. Duct leakage is an air flow rate, measured in cubic feet per minute. Usually, one measures the rate at which air must be blown into a duct system with sealed registers, to maintain some standard static pressure within the duct.

Equipment for Duct Leakage Testing

Duct leakage tests require specialized equipment. At a minimum, you will need a **duct blower** (an adjustable calibrated fan) and a **digital manometer** (a pressure gauge). Another piece of equipment, the **blower door** (a larger version of the duct blower) is primarily used in testing for air leakage in the house envelope, but it can be very useful in checking for duct leakage as well. Before discussing the duct leakage test, it will be helpful to become familiar with these tools.

Digital Manometer. The digital manometer is an electronic device that can measure pressure differences to an accuracy of ± 0.1 pascal. The pascal, abbreviated Pa, is the metric unit of pressure. One pascal is a very small pressure, equal to 1/250 inch of water column or 0.00001 atmosphere. It is the most commonly used unit of pressure in the duct-repair business, because it is small enough that typical duct pressures can be given in whole numbers and not tiny fractions. A typical digital manometer is housed in a hand-held box, often with two “channels” so that one instrument can measure two different pressures (Figure 1). Each channel has an input port and a reference port, to which hollow plastic tubes can be attached. The manometer reads the difference in pressure between the places where the free ends of the tubes are located. If the manometer is itself at one of the desired locations, the input or reference port can be left open and one plastic tube run to the other location. The pressure difference indicated is the input port pressure minus the reference port pressure. It is common to speak of a pressure at location X (linked by a plastic tube to the input port) *with respect to* the pressure at location Y (linked by a plastic tube to the reference port).

If the pressure that is to be measured is in still air, the end of the plastic tube at that location can simply be left open. This would be the case for pressures at various places within the living space of the house, the basement, the crawl space, or the attic. In locations such as ducts where air is moving, more care is needed to ensure that the static pressure is measured without contamination by the velocity pressure, which is generated by the movement of the air. Therefore, an appropriate pressure probe is required. The static pressure tap of a standard pitot tube can be used. Alternatively, a simpler probe consisting of a copper tube with 90° bend, the tip section closed off at the end and two small holes drilled perpendicular to the tip section, can be used. In either case the tip of the probe is inserted into the duct so that it faces “into the wind” of the air stream inside. Fortunately, in residential duct systems, the velocity pressure is typically one or two pascals, which is usually much smaller than the static pressure, which tends to be on the order of tens of pascals.

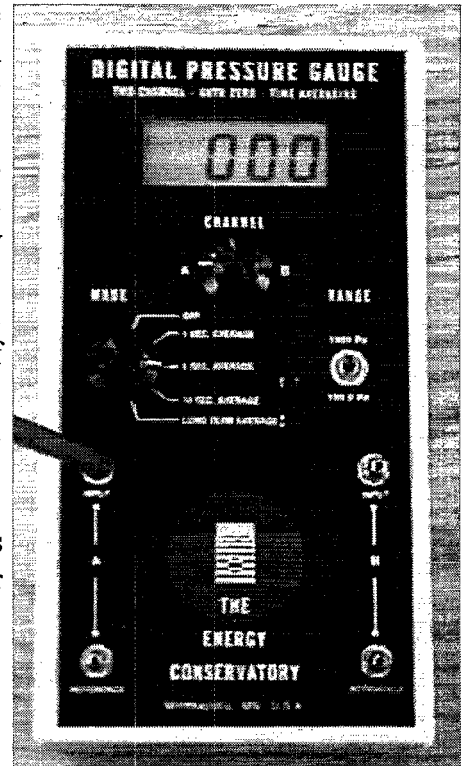

Figure 1 Digital Manometer

Duct Blower. The duct blower is a calibrated adjustable-speed fan that is used to blow air into one opening in a duct system that has all its registers temporarily sealed over. (Typically this register sealing is done with pieces of easily removable plastic tape or magnetized mats.) The outlet end of the duct blower (which terminates in a length of flex duct) is attached to an opening in the duct system (either the fan-access opening at the air handler or a large register). The connection between the duct blower and the duct system must be done in such a way that air can't leak out through portions of the opening that aren't covered by the flex duct. The most common procedure is to cut a piece of cardboard so that it just fits the opening into the duct system and then to cut a circular hole in the cardboard that's the same diameter as the flex-duct piece. The cardboard is taped to the edges of the opening and then the end of the flex-duct piece is taped to the hole. A plastic flange is supplied with the duct blower to facilitate this connection. This provides a good seal, insuring that any air that passes through the fan is blown into the duct.

Figure 2 shows the duct blower attached to a forced-air system at the fan-access opening of a gas furnace. With the digital manometer set up to read the fan-throat pressure and the pressure in the duct, the test is ready to go.



Figure 2 Duct Blower at fan access opening with use of cardboard "custom-cut" mounting.

To make the measurement, the duct blower is turned on and its fan speed adjusted until the pressure in the ducts is 25 Pa. This enables a duct leakage flow rate to be read off from the duct blower calibration chart. This flow rate is often designated by the symbol CFM_{XX}, where XX is the pressure at which the measurement is taken. In our example, we would speak of a "CFM₂₅."

The duct blower is supplied with several "rings" that can be mounted on the inlet side of the fan. These rings have different-sized holes that are used to "stop down" the opening, much like f-stops on a camera. They permit the same fan to measure a wide range of air flows, typically from 20 cfm to 1700 cfm.

Other Helpful Equipment. Two other pieces of test equipment are sometimes used in connection with duct leakage testing. These are the **blower door** and the **flow hood**.

The blower door is another type of calibrated, adjustable-speed fan, larger than the duct blower. It is placed in a tight-fitting hole in a temporary baffle set up in an exterior doorway (Figure 3). Predating the duct blower, it was invented twenty years ago to measure whole-house air leakage rates. When the fan is turned on with all the windows and any other outside doors closed, it creates a pressure difference between the inside and the outside of the house. The calibration of the fan allows the operator to read off how much air is being blown through the fan. The principle is the same as with the duct blower. Envelope leakage is characterized by the amount of air flow needed to maintain a given pressure inside the house. Typically 50 Pa is used as the standard pressure, so it is common to hear of an “envelope CFM50.” As with the duct blower, several “rings” are supplied with the blower door fan to permit stopping down the fan orifice; this permits tighter envelopes with smaller CFM50 values to be measured accurately. Although the main purpose of the blower door is not to measure duct leakage, it is used to assist in some types of duct-leakage tests.



Figure 3 Blower Door mounted in entryway of home in use during duct leakage evaluation tests.

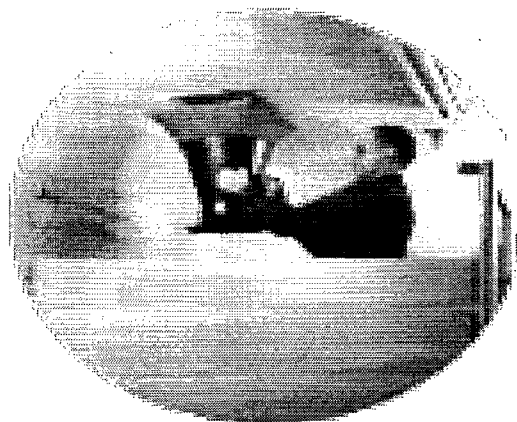

Figure 4 Flow Hood

The flow hood (Figure 4) consists of a canvas-covered metal frame in the form of an upside-down pyramid with the pointed end cut off. An array of measurement tubes is located inside the hood. The large open end of the pyramid is held against the opening of a register, so that all air entering or leaving the register must also pass through the flow hood (follow flow hood instructions). A digital output is provided that permits the air flow in cubic feet per minute (cfm) to be read off. The flow hood has a variety of uses in research and diagnostic testing. One of the alternative tests for system fan flow rate described in this manual uses a flow hood.

Duct Leakage Test Procedure

The test described in this manual has three parts. The first part is a “basic duct-blower test” that is one of the options for testing in ASHRAE Standard 152, and which has been adopted for use in a certification test used by the U.S. Environmental Protection Agency in its Energy Star program. This part represents the bulk of the test in terms of labor. The second part of the test is a simple measurement of the pressure difference across the system fan. This is called, naturally enough, the “system-fan pressure difference.” The third part of the test provides information about whether the leakage is concentrated in the supply side or the return side of the duct system, or is more or less evenly split between them. This part of the test is called the “dominant duct leakage test.” Detailed protocols for these procedures are provided in Appendix 1 at the end of this booklet.

The Basic Duct Blower Test. The Basic Duct Blower Test provides a single numerical value for the total air leakage rate of the whole duct system when it is pressurized to a standard pressure (usually 25 Pa). The basic test treats all leakage the same, whether it comes from the outside or from the living space. That’s a limitation, because leakage to the living space doesn’t really represent lost energy. It’s very useful information nevertheless. In a new house with a duct system that is designed to be “tight,” this test can be used to assure that the actual system meets the specification. In many



Figure 5 Alternative Duct Blower attachment using a large register.

older homes, the ducts are all outside the conditioned space and one can assume that nearly all the leakage is also to the outside. A big merit of this test is that it is usually quite quick and easy to do, which should enable builders and contractors to add it to their list of frequently used tools.

To prepare for this test, it is necessary to seal all the registers temporarily. This is most easily done using a commercially available “duct mask” that consists of a roll of plastic with adhesive on one side. The adhesive is sticky enough to hold the plastic to the face of the register during the test, but forgiving enough that it can be pulled off without taking the paint away with it.

The next step is to attach the duct blower to the duct system. A method of attachment at the air handler has already been described and shown in Figure 2. If it is not convenient to attach the duct blower at the air handler, an alternative is to use a large register, as shown in Figure 5.

The test installation is completed by inserting a pressure probe into the duct system. If you are planning to do only the Basic Duct Blower Test, this probe can be inserted through a register on the side of the system opposite to

that on which the duct blower is attached. Since the duct blower is usually attached on the return side (either at the air handler or a large return register), this means that you would select a supply register. Try to find one that is as large as possible, close to the supply plenum, and with as short a runout as possible from the main supply trunk. Make sure that the runout to the selected supply register is not disconnected in any way.

If you are planning to go on to do the second and third parts of the leakage test, to get an approximate reading on the actual leakage rates on the supply and return sides separately, then you should plan to insert the probe at the supply plenum, because you will need a probe there later, and it will save a little time to make one probe do double duty. (In the minority of cases where the duct blower was attached on the supply side of the duct system, insert the probe at the return plenum.)

A few words are in order here about the insertion of a pressure probe into the supply or return plenum. Sometimes it will be possible to find a way to do this without adding a test hole. The return plenum is often accessible via the filter slot. The supply plenum is less likely to be easily accessible, but in some cases there may be a register with a short runout directly from the plenum.

Often, though, it will be necessary to drill a test hole. If the duct is of sheet metal, care should be taken to cover the hole neatly, after the test is completed, with a small piece of metal-foil duct tape. Duct board can be drilled through and then repaired afterward with a daub of mastic and a piece of metal-foil tape. Flexible duct should not be pierced. It is a good idea to explain to the homeowner the need for the test hole, with assurance that it will be covered over before the testers leave. If possible, place the test hole in an inconspicuous place, if the ducts are in a portion of the house, such as a basement, that is visited by the occupants.

Warning: when drilling a hole into ductwork, make sure you do not hit the cooling coil or a refrigerant line. These are often installed in or near the supply plenum.

With this equipment in place, the duct blower motor is turned on and its speed increased until the pressure in the duct (the pressure probe in the plenum) reads 25 Pa. The pressure at the duct-blower fan throat is then measured (using the second channel of the digital manometer) and converted to an air flow rate (in cfm) using the calibration chart supplied with the duct blower. If the flow rate is "off the chart" it will be necessary to change the ring on the duct blower, to the ring size appropriate to the leakage found within this particular duct.

The result of this simple measurement is a total-leakage "CFM25" rating for the whole duct system.

If you are participating in an agency-sponsored duct efficiency program, this may be the only information you will need to determine whether or not the duct system meets a preset criterion. However, it is possible to improve the quality of the information quite a bit at very little cost in added time and effort. This is discussed in the following sections.

It should be noted that if the CFM25 is low (say, less than 100 cfm), the pressure in the duct will not change much from one point to another, and very nearly the same CFM25 value should be expected

no matter where in the duct the pressure is measured. If the ducts are leaky, however, the pressure in the duct may vary significantly from one place to another, because there will be significant air flow from the point where the duct blower is attached to the locations of the major leaks. In that case, though, all the measured CFM25 values will indicate that the ducts are leaky and in need of repair; they will just disagree somewhat on exactly how leaky they are.

Modification for Outside Leakage. The test as described above measures the leakage from all holes in the duct system at 25 Pa pressure difference, regardless of whether these are inside or outside the living space. However, from an energy-efficiency point of view, the only holes that matter are those that lead to spaces outside the conditioned zone of the house. This is because air leakage to the inside of the house provides useful heat (or cooling) just as much as the air coming out of the registers. Of course, huge leaks to inside might cause a problem by making the system difficult to balance; but short of that, leakage to inside (or from inside in the case of the return ducts) should not be a problem and need not be considered in evaluating duct efficiency.

If all of the ductwork is clearly outside the conditioned space, then there should be little or no leakage to inside. But in cases where some of the ductwork is inside or adjacent to the living space, leaks to inside should be excluded from the measurement. This includes cases where parts of the building, such as joist spaces or chases, are used as ducts—a common, though not recommended, practice.

This is where the blower door comes in. At the same time that the duct system is being prepared for the basic duct blower test, a blower door is set up in one of the outside doorways. The blower door is used to pressurize the house to 25 Pa. The duct blower then is turned on and its speed increased until the pressure difference between the duct and the living space is zero. Because of the zero pressure difference, leaks to inside are eliminated, and only the leakage to outside remains to be measured.

The rest of the test is the same as described in the previous section. The test protocol in Appendix 1 describes the test with and without the use of the blower door. In deciding whether to include the blower door in the test, the following points should be kept in mind:

- The test without the blower door is conservative; that is, the CFM25 measured without the blower door should be equal to or greater than the CFM25 with the blower door.
- If placement of ducts within the conditioned space has been adopted as an energy-efficiency strategy, the blower door should always be used in testing the system, because otherwise the builder will get no credit for putting ducts in the living space.

System-Fan Pressure Difference. The reason for measuring the pressure difference across the system fan is that some duct systems operate at higher pressures than others. Two duct systems with the same CFM25 can have quite different leakage rates if the actual range of pressures in one is

much higher than the range of pressures in the other. For a duct with a given set of cracks and holes, the greater the pressure, the more air will leak from these cracks and holes.

The measurement itself is quite simple. Unseal all the registers and remove the duct blower. Make sure that all parts of the system have been returned to their normal operating condition, with one exception. Leave the pressure probe in the supply plenum. Then install another pressure probe in the return plenum. Run a plastic tube from the return-plenum pressure probe to the reference port of the manometer, on the same channel where the supply-plenum pressure probe is already connected to the inlet port. Turn on the system fan. Measure the pressure difference between the supply and return plenum pressures under normal system operation.

In some systems, the system fan runs at different speeds in the heating and cooling modes. Under such circumstances it is necessary to make separate measurements for heating and cooling. Often, the system fan switch activates the cooling-mode fan speed. If in doubt, activate the heating and cooling modes separately using the thermostat.

If the measured pressure difference across the system fan is 100 Pa, our best estimate of total duct leakage will equal the CFM25 value, because on average the supply and return plenum pressures will each equal 50 Pa. The usual assumption is that the average pressure “seen” by the leaks is half the plenum pressure, or 25 Pa in this case. Of course, the total pressure difference of 100 Pa could indicate some other combination of supply and return pressures, either because the supply and return plenum pressures are not equal and opposite as assumed, or because the leaks on each side are not, on average, at half the plenum pressure. Some of these uncertainties will tend to cancel out, and to the extent that they do not, they will just have to be accepted unless one wishes to take considerably more time measuring the duct leakage in a research mode.

If the measured pressure difference across the system fan is greater than or less than 100 pascals, it will be necessary to adjust the measured CFM25 to reflect this. Appendix 1 explains how to use the system-fan pressure difference measurement to make this correction.

Dominant Duct Leakage Test. The third step in the process is called the dominant duct leakage test. This test does not involve either the duct blower or the blower door. It just uses a digital manometer and a plastic tube. One end of the plastic tube is run into the attic and the other end is connected to the reference port of the digital manometer. The input port is left open. The equipment is now set up to measure the pressure in the house with respect to the attic. A series of pressure measurements is made, using the 5-second averaging feature on the manometer. Some of these pressures are measured with the system fan on and others with the system fan off. The point of the test is to determine whether the duct leakage to the outside is more-or-less the same on the supply and return sides of the system, or whether one side has the lion’s share of the leakage.

The way the test works is this. If the return side of the duct system leaks more than the supply side, the duct system will be taking in more leakage air (into the return ducts) than it loses (from the supply side). This excess leakage air has nowhere to go but into the house, and when it does it tries

to “blow the house up like a balloon.” In other words, the pressure in the house goes up when the fan is turned on.

On the other hand, if the pressure in the house goes down when the fan is turned on, it means that the supply ducts leak more than the return ducts.

It should be noted that this test is only affected by the balance of leakage between the ducts and the outside. Leakage between the living space and the ducts is just like flows through the registers, and does not affect the change in house pressure when the fan is turned on. It should also be emphasized that the test only works if the attic is vented to the outside.

This is a fairly simple test to do, but a little care is needed nevertheless. This is because the shifts in house pressure are often quite small, usually one pascal or less, and the test is quite sensitive to sudden changes in the speed or direction of the wind outside the house. To get around this, the normal procedure is to take multiple measurements to make sure that one is seeing the real effect of the duct leakage over the “noise” of air turbulence outside the house. A protocol has been developed that involves taking 30 five-second measurements with the system fan on and another 30 measurements with the system fan off. These are alternated with each other in a way that is designed to match up pairs of fan-on and fan-off measurements as closely in time as possible, to minimize wind-shift effects between measurements, consistent with a reasonable amount of time for the whole test.

Using the Results. The results of the duct leakage tests can be used in a variety of ways. If the only objective is to determine whether the total duct leakage CFM25 meets some preset criterion, then the Basic Duct Leakage Test can be performed and the rest of the procedure dispensed with. On the other hand, if it is desired to estimate the actual leakage on each side of the duct system with a view to determining how much good one can do by fixing it, then all three parts of the test should be done. This will provide a good value for the total leakage and an approximate “split” of this into supply-side and return-side leakage. See Appendixes 1 and 2 for more detailed information on these alternatives.

System Fan Flow

The impact of duct leakage on distribution efficiency is determined, not by the size of the leakage values themselves, but by how they compare with the total air flow through the air handler. For systems with air conditioning, measuring system fan flow is especially important because **low fan flow is one of the most common causes of poor performance and efficiency in the air-conditioning equipment.** If the equipment and the duct system are both faulty, you can dramatically improve system performance by setting things right.

A variety of methods have been used to measure air flow in ducts. In commercial systems there is often a very long trunk duct leading out from the equipment. In such cases, a grid of measurements with a pitot tube or hot-wire anemometer, averaged over the duct cross section, can give an accurate

result. In residential systems, however, the conditions are seldom favorable for this test. An approximate value of the air flow rate (in cfm) can be found as 0.9 times the heat output rate of the furnace (in Btu/h) divided by the temperature rise across the heat exchanger (in °F). However, this method tends to give inaccurate results unless applied with extreme care.

ASHRAE Standard 152P specifies a method that uses the duct blower in conjunction with a temporary barrier between the supply and return sides of the duct system. Although this method is generally quite accurate, placing the barrier can be time-consuming. Therefore, in preparing this manual we have included other air-flow tests that do not require the barrier. Three tests are described briefly below, with further information provided in Appendix 1.

Flow-Hood Test. The basis of the flow-hood test is to measure the air flow into the return registers and then to add an additional air flow to account for leakage into the return duct. This is a reasonably accurate method if the duct system is “tight.” For leaky ducts, accuracy is compromised by the larger uncertainty in the leakage measurement. Nevertheless, it can provide a preliminary air flow measurement that can warn of a serious low-flow situation. Also, it is easy to repeat the test after the ducts are repaired to get a more accurate final value.

Flow-Plate Test. Recently a commercial product has been developed, with assistance from a U.S. Department of Energy program, that uses a test frame that can be inserted into the slot in which the air filter is normally located. Air flowing through the frame generates a pressure difference that can be measured with a digital manometer and converted to an air-flow rate using a calibration chart. Generically, this is a sound approach. Although it is not appropriate for this manual to endorse specific brand-named products, as a general rule it will pay builders and contractors to keep abreast of new developments in the technologies for diagnosing, installing, and repairing duct systems.

Duct Blower Pressure-Matching Test. ASHRAE Standard 152 specifies a method that uses the duct blower as a test instrument. It has the merit of being quite accurate (which the flow hood method sometimes is not) and it uses existing and proven technology (the duct blower). It does, however, require the use of a temporary barrier between the supply and return sides of the duct system. Although in many systems (such as those with a filter slot near the air handler) it is not difficult to install this barrier, it can be a problem in others (such as systems with the air handler in the attic and the filter at the return grille).

DECIDING WHAT TO DO

The final step in the procedure is to propose a course of action to your customer. There are three general approaches to making this decision. They are:

- Rules of Thumb
- Program Guidelines
- ASHRAE Standard 152

Rules of Thumb

Acknowledging the roughness of any rule of thumb when it attempts to cover a wide range of cases, the following suggestions can be adopted when better methods are not available:

Rule 1. Reduce duct leakage until the sum of the supply leakage to outside and return leakage from outside is less than 10% of the system fan flow rate.

Rule 2. Add R-8 insulation to any uninsulated ducts in unconditioned spaces. Add enough insulation to attic ducts to bring the total insulation level to R-12.

These rules are not perfect. The customer will sometimes benefit from reductions in duct leakage to levels below what is specified in Rule 1 or insulation levels above those given in Rule 2. Occasionally a duct system will be so problematic that achieving the levels specified will be impossible within reasonable cost constraints. But they are not bad rules of thumb if used judiciously and, where possible, in conjunction with program guidelines and/or ASHRAE Standard 152.

Program Guidelines

Residential energy-efficiency programs run by federal, state, and private-sector agencies are increasingly including duct efficiency in their portfolios of system upgrades. In the interest of simplicity, these programs often provide their own guidelines to be used in assessing the need for duct repairs. When a builder or contractor is participating in such a program, the guidelines of the program should be adhered to. If there is doubt whether the guidelines truly work to the best interests of the homeowner, ASHRAE Standard 152 can be used to assess the impacts of various proposed changes to the guidelines. These can then be discussed with the program administrators. However, as long as one is a participant in the program, the guidelines of that program should be used until they are revised.

ASHRAE Standard 152

Standard 152, developed by the American Society of Heating, Refrigerating, and Air Conditioning Engineers (ASHRAE), provides a means for determining the efficiency of residential duct systems in the heating and cooling modes. Although air leakage is a major cause of duct inefficiency, other factors such as heat conduction through the duct walls, influence of the system fan on pressures within the house, and partial regain of lost heat, are also important. Standard 152 takes these other factors into account. It starts with the measured duct leakage rate, but then adds parameters that describe the house as a system to calculate duct efficiencies.

The calculations that Standard 152 uses to obtain duct efficiencies are quite complicated. Fortunately, a web site is available that can enable the user to bypass all the mathematical complexity. This is described in Appendix 2. Aside from the duct leakage and fan flow rates, the

data inputs required by Standard 152 are relatively few in number and easy to obtain. They include a rough value of the conditioned floor area, the amount of insulation on the ducts, and the capacities of the heating and cooling equipment.

The output of Standard 152 is called distribution efficiency. This is defined as a ratio of two energies. Specifically, distribution efficiency equals the input energy needed to heat or cool the building if the duct system were perfect, divided by the amount of input energy needed to heat or cool the building with the actual duct system, under the same conditions.

Distribution efficiency is defined in this way so that it can account not only for direct losses of heat or cooling from the ducts but also for the indirect impacts that the duct system may have on the efficiency of the equipment or on the heating and cooling loads themselves. Examples of situations where these indirect impacts are too important to ignore include systems with air-to-air heat pumps, ducts in unconditioned basements, or where the supply- and return-side leakage values are very different.

APPENDIX 1. TEST PROTOCOL FOR DUCT LEAKAGE AND SYSTEM FAN FLOW

The procedures in the first part of this appendix include basic test for estimating duct leakage. The second part covers some advanced tests appropriate as inputs to ASHRAE Standard 152.

PART I: DUCT LEAKAGE

This part gives instructions for the basic duct blower test. Although not suitable for use with ASHRAE Standard 152, it provides important and useful information and may be specified in various duct leakage evaluation procedures.

Basic Duct Blower Test Description

Test Objective: Measure total leakage rate (to inside and outside) of the whole duct system (registers sealed) at 25 Pa pressure.

Method: A benchmark leakage rate at 25 Pa pressure is determined using a duct blower. A probe (typically in the supply plenum) is used to measure the pressure in the duct.

Procedure:

1. Turn off the air handler fan of the duct system.
2. Select a place of attachment for the duct blower. The fan access opening of the furnace or heat pump is usually a good choice. Another good choice is a single large return register. If neither of these is accessible, choose the largest register closest to the air handler. Attach the duct blower at this location. It will usually be necessary to prepare a temporary baffle of cardboard or other stiff material as an interface between the duct blower outlet and the attachment opening.
3. Assuming that the duct blower is attached to the duct system on the return side of the system fan, insert a static pressure probe into the supply plenum. (If the duct blower is on the supply side, insert the probe into the return plenum.) Run a plastic tube from the probe to the input port of a digital manometer.
4. Seal all other supply and return registers.
5. Make sure that any spaces with ducts are vented to the outside, if necessary by opening a door or window. The conditioned space should also be opened to the outside.
6. Adjust the duct blower so that the reading from the pressure probe is 25 Pa. Record the flow through the duct blower.

Modified Duct Blower Test–Leakage to Outside Only

If some of the ductwork is within the conditioned space, a more useful value of the duct leakage will be obtained if any leakage to inside is “zeroed out” using the blower door. The procedure is similar to the above in most respects. Differences are shown in italics.

Test Objective: Measure leakage rate to/from outside of whole duct system (registers sealed) at 25 Pa pressure.

Method: A benchmark leakage rate at 25 Pa pressure is determined using a duct blower in combination with a blower door. A probe (typically in the supply plenum) is used to measure the static pressure in the duct.

Procedure:

1. Turn off the air handler fan of the duct system.
2. Select a place of attachment for the duct blower. The fan access opening of the furnace or heat pump is usually a good choice. Another good choice is a single large return register. If neither of these is accessible, choose the largest register closest to the air handler. Attach the duct blower at this location. It will usually be necessary to prepare a temporary baffle of cardboard or other stiff material as an interface between the duct blower outlet and the attachment opening.
3. Assuming that the duct blower is attached to the duct system on the return side of the system fan, insert a static pressure probe into the supply plenum. (If the duct blower is on the supply side, insert the probe into the return plenum.) Run a plastic tube from the probe to the input port of a digital manometer. *Locate the manometer within the conditioned space or run a plastic tube from the conditioned space to the reference port of the manometer.*
4. Seal all other supply and return registers.
5. Make sure that any spaces with ducts are vented to the outside, if necessary by opening a door or window. *The conditioned space should be closed off from the outside.*
6. *Set up a blower door in an outside doorway leading into the living space. Adjust the blower door so that the house is pressurized or depressurized to 25 pascals.*
7. *Adjust the duct blower so that the reading from the pressure probe is zero.* Record the flow through the duct blower.

System Fan Pressure Difference Test Description

Test Objective: Measure pressure difference across the system fan, i.e., supply plenum pressure minus return plenum pressure..

Method: Static pressure probes in the supply and return plenums are connected to a digital manometer, which is used to measure the pressure difference.

Procedure:

1. Leave the supply-plenum pressure probe in place, connected to the input port of a digital manometer.
2. Unseal all registers, remove the duct blower, and restore the system to normal operating condition.
3. Insert a static pressure probe into the return plenum, and connect this via a plastic tube to the reference port of the same channel on the digital manometer.
4. Activate the system fan and record the supply-to-return plenum pressure difference. If the fan speed varies between the heating and cooling mode or if there is more than one fan speed for a given mode, do this separately for each operating condition.
5. Remove the pressure probes from the duct, and if it was necessary to drill a hole through the duct to insert a probe, seal using mastic and/or metal foil tape.

Dominant Duct Leakage Test Description

Test Objective: Determine by measurement which side of the duct system (supply or return) has more leakage than the other, or establish that they have roughly equal amounts of leakage.

Method: The response of the house pressure to activation of the system fan is measured 30 times, with the dominant leakage determined by whether the house pressure usually goes up or down when the fan is turned on.

Procedure:

1. If the attic is well ventilated, run a plastic tube into the attic and connect the other end to the input port of a digital manometer located in the conditioned space. If there is no ventilated attic, run the tube into a ventilated crawl space or a garage with an outside door “cracked open” about two inches.

2. With the system fan off, take five measurements of the house pressure. Use five-second averages. Record values in the house pressure chart (page 21).
3. Turn on the system fan and wait 20 to 30 seconds. Take ten measurements of the house pressure. Use five-second averages. Record values in the house pressure chart.
4. Turn off the system fan and wait 20 to 30 seconds. Take ten measurements of the house pressure. Use five-second averages. Record values in the house pressure chart.
5. Repeat Steps 3 and 4.
6. Repeat Steps 3 and 4 once again.
7. Finally, with the system fan off, take five measurements of the house pressure. Use five second averages. Record values in the house pressure chart.
8. The house pressure chart ensures that fan-on and fan-off measurements are paired up, with measurements in a pair taken as close in time as practicable. Inspect each measurement pair, and circle whichever is greater.* If they are the same, don't circle either one.

**Important. Remember that when both positive and negative numbers are involved, as they are with pressures, the greater number is the one to the right on the number line. Thus, 0 is greater than -1, -1 is greater than -2, and +1 is greater than -1. When both numbers are positive, the obvious relationship holds, for example, +2 is greater than +1.*

9. Follow the directions beneath the house pressure chart to determine whether the leakage is supply-dominant, return-dominant, or balanced. Check the appropriate box in the Dominant Duct leakage table on page 20.

Calculations

The protocol sheet runs through the necessary calculations. In brief, the CFM25 measured in the Basic (or Modified) Duct Leakage Test is corrected to a best estimate of actual leakage using the pressure difference across the system fan. This is then split into approximate supply and return leakage fractions on the basis of the dominant duct leakage test.

DUCT LEAKAGE TEST DATA SHEET

Basic Duct Blower Test

Pressure in Duct (Pa) with respect to Outside	Duct Blower Fan Throat Pressure (Pa) w/r/t Space Surrounding Duct Blower	Duct Blower Ring Number (0 for open fan)	Duct Blower Air Flow (cfm) from Calibration Chart
Target: 25			

Modified Duct Blower Test (Optional, Measures Leakage to Outside Only)

Pressure in Duct (Pa) with respect to Conditioned Space	Duct Blower Fan Throat Pressure (Pa) w/r/t Space Surrounding Duct Blower	Duct Blower Ring Number (0 for open fan)	Duct Blower Air Flow (cfm) from Calibration Chart
Target: 0			

System Fan Pressure Difference Test

Pressure Difference Across System Fan (Supply Plenum Minus Return Plenum), Normal System Operation (Pa)

Dominant Duct Leakage Test (Use Data Sheet on Other Side)

Check appropriate box to indicate which side has dominant leakage

Supply Dominant Balanced
 Return Dominant

Calculations

Line	Item Description	Enter Value	Units
1	Leakage CFM25 from Basic or Modified Test (Circle Which)		cfm
2	Pressure Difference Across System Fan		Pa
3	Divide line 2 by 100		---
4	Take the square root of line 3		---
5	Multiply Line 1 by Line 4. This is supply + return leakage		cfm
6	Dominant Duct Leakage Factor. If Supply Dominant, write 0.7. If Return Dominant, write 0.3. If Balanced, write 0.5.		---
7	Multiply Line 5 by Line 6. This is Supply Leakage CFM.		cfm
8	Subtract Line 7 from Line 5. This is Return Leakage CFM.		cfm

PART II. SYSTEM FAN FLOW

Select one of the following methods of measuring system fan flow:

A. Flow Hood Test

Objective: Measure the air flow rate at the system fan, under normal operating conditions.

Method: The air flow into the return registers is measured using a flow hood. The leakage air flow rate into the return duct is taken from the duct leakage test. The sum of these two is the desired flow rate.

Procedure:

1. With the system operating normally in the desired heating or cooling mode, measure the air flow rate into each return register using an appropriately calibrated flow hood.
2. From the duct leakage test as described above, take the measured total return leakage, from Line 8 of the calculations box on page 20, using leakage CFM25 (Line 1) from the Basic Duct Leakage Test (without blower door).
3. Add the air flows from (1) and (2) to obtain an estimated system fan flow rate in cfm.

B. Flow Plate Test

Objective: Measure the air flow rate at the system fan, under normal operating conditions.

Method: A special "air handler flow plate" (AHFP) is inserted into the duct at the location of the air handler, upstream of the fan.

Procedure:

1. Install a static pressure probe into the supply side of the ductwork.
2. With the system operating normally, record the static pressure at this point.
3. Assemble the flow plate and install in the duct, normally in the filter slot, taking care that no bypass air flow paths exist around the edges of the plate.
4. Turn on the system fan and record the static pressure at the same point as in Step 2.
5. Measure the pressure across the flow plate.
6. Use the three pressures measured in Steps 5, 6, and 7, together with the manufacturer's calibration chart, to calculate the air flow under normal operating conditions.

C. Duct-Blower Test for System Fan Flow Rate (from ASHRAE Standard 152P)

Objective: Measure the air flow rate at the system fan, under normal operating conditions. .

Method: A pressure in the duct at or near the supply plenum is measured while the system is operating normally. The return side of the duct system is then blocked off and a duct blower installed at the air handler. With the system fan on, the duct blower motor is then adjusted until the supply-plenum pressure is the same as before.

Procedure:

1. With the system fan on in the heating or cooling mode for which the air flow rate is required, measure the pressure difference between the supply plenum and the conditioned space. Make sure that the static pressure probe in the supply plenum is firmly attached so that it does not move during the test.
2. Turn off the system fan and block the return duct connection to the air handler fan, such that it does not draw any air from the return duct system.
3. Attach a duct blower to the duct system at the air handler access opening upstream of the system fan.
4. Turn on the system fan and adjust the duct blower motor until the pressure between the supply plenum and the conditioned space matches the value measured in Step 1.
5. Record the air flow through the duct blower. This is the system fan flow rate under normal operating conditions.

Note: it may not be possible to achieve a high enough flow rate through the duct blower to match the supply-plenum pressure as called for in Step 4. In that case, Standard 152 gives a procedure for pro-rating the flow rate measured at the maximum duct blower motor speed.

SYSTEM FAN AIR FLOW TEST DATA SHEET

Choose one of the following tests and go to the appropriate section:

Flow-Hood Test Flow-Plate Test Duct-Blower Test (Standard 152P)

Flow-Hood Test

Return Register	Measured Flow Rate, cfm	Return Register	Measured Flow Rate, cfm	Return Register	Measured Flow Rate, cfm
1		3		5	
2		4		6	
Sum of Measured Flow Rates from All Return Registers:					
Total Return Leakage Rate from Duct Leakage Test (using Basic Duct Leakage Test, without blower door)					
System Fan Air Flow Rate (sum of previous two lines)					

Flow-Plate Test

1. Test Point Pressure, Filter Installed	Pa
2. Test Point Pressure, Flow Plate Installed	Pa
3. Divide Line 1 by Line 2, and Take Square Root of the Result	
4. Air Flow Through Flow Plate (Calibration Chart)	cfm
5. Normal System Air Flow (Line 3 X Line 4)	cfm

Duct Blower Test for System-Fan Air-Flow Rate (from ASHRAE Standard 152)

Target Pressure Difference Between Supply Plenum and Conditioned Space	Pa	
Duct Blower Data:		
Ring Number (Usually Open Fan)	Duct Blower Throat Pressure (with respect to surrounding space)	Duct Blower Air Flow, cfm (from calibration chart)
	Pa	cfm

APPENDIX 2. USING ASHRAE STANDARD 152

ASHRAE Standard 152 can be a very useful tool for figuring out how much good will be accomplished by various choices in duct retrofits. Suppose, for example that we fix half the leaks in a duct system. Will it be worthwhile to go further, even at some trouble and expense? Should we also add insulation? Aside from asking these questions about specific systems, it can also be used to play “what-if” games about the kinds of situations you typically meet up with. This will reinforce your intuition about what is likely to make sense and what isn’t.

The equations in Standard 152 are quite complicated, but fortunately there is a calculation engine on the Internet that is simplicity itself, once you have values for the duct leakage rates and the system fan flow. The web address for this web site, which is maintained by Lawrence Berkeley National Laboratory, is <http://DUCTS.LBL.GOV> .

A facsimile of the web page output is given in Table A2-1. It is set up to accept either IP (inch-pound) or SI (metric) units. The following is a rundown of the information required to activate it. It will be assumed that you are using IP units.

House Information

Enter the interior conditioned floor area of the house, in square feet. This need not be super-accurate. A value to the nearest 100 square feet is good enough.

Click on the pull-down menu beside Location of house and scroll down to the state and city nearest to the site. Click on the chosen location.

Duct Location Information

The Standard 152 calculation engine needs to know where the ducts are, because some locations are more energy-efficient than others. If all the supply ducts are in one particular type of space, enter 1.0 in that box. If the ducts are split among spaces, enter the appropriate fractions in each type of space. If some of the ducts are in the conditioned space, the sum of these fractions will add up to one minus the fraction that is in the conditioned space. Strictly speaking, these fractions are based on surface area of ductwork, not length. If the ducts run through more than one kind of space, the fractions in each type of space may be “eyeball estimated.”

Once these fractions have been entered for the supply ducts, do the same for the return ducts.

The web site lists “default values” for the regain factors for the various types of spaces. It lets you change these, but unless you are well versed in the standard, it is best to leave them alone.

Duct Information

Standard 152 allows you to use a “default algorithm” to calculate the total surface areas of supply and return ducts. Actually measuring these surface areas can be quite time consuming, so unless you already know these, for example from a design calculation sheet, it is probably a good idea to use the default option. Just enter the number of return registers and click on “Yes” for the query “Use Default for Supply and Return Duct Surface Area.” If you do that, you don’t have to enter the supply and return surface areas.

Under “type of material” click on what the majority of the ductwork is made from, either sheet metal or any combination of flexible duct and ductboard. (Standard 152 uses this information to account for off-cycle losses due to thermal mass. Sheet metal can store more heat than other materials.) If the system has some ducts of each kind (which often happens) then go by whichever material predominates.

Next enter the insulation levels of the ducts. Consider the supply and return ducts separately. If the ducts are uninsulated, enter “1.” If they have standard duct wrap, which is usually R-4, enter “4”. If some different R-value is indicated on the insulation, use that. If some of the ducts on a given side (supply or return) are insulated and some not, use an intermediate value.

If the ducts are located in the attic, then their efficiency in the cooling mode depends on how hot the attic gets. This will in turn depend on whether the attic is well ventilated or not and also on whether certain measures have been taken to reduce attic temperatures. Standard 152 recognizes three of these kinds of measures: radiant barriers, “white” roof coatings, and tile roofs. In most cases, you can check Yes on the “well vented” question and No on the “temperature reduction methods” one.

Heating Equipment Information

This and the next are the sections where the most important information is entered. There is a pull-down menu for type of heating system. The choices are gas, electric, and heat pump. Click on the type of heating system you have. Click on “gas” for any combustion furnace, whether natural gas, propane, or oil fired.

Next enter the capacity of the heating equipment in Btu/h. This can usually be obtained from the nameplate. If the nameplate on a combustion furnace gives both input and output, use the output rate.

Under “heating equipment fan flow” enter the system fan air flow rate as measured using one of the methods described above.

In the next two boxes, enter the supply and return duct leakage rates to/from outside, measured using the method described above.

Cooling Equipment Information

This section is similar to the heating equipment side, except that the possibility of a two-stage air conditioner is allowed for. Most systems are single-capacity systems. In that case, check “single” after the initial question and enter values only in the column marked “Normal.” If it is a two-speed unit, values for both “normal” and “high” speeds will need to be entered. The fan flow and duct leakage rates (again, to or from outside) as measured under the cooling-mode fan speed condition, are entered next.

The last two questions are used by the standard in considering the impact of the duct system on equipment performance. If you don’t know what kind of control system the air conditioner has, check “orifice/cap tube.” If you know that the duct system was designed according to a recognized procedure, such as that in Manual D of the Air Conditioning Contractors of America, check “Yes” to the next question. Otherwise, check “No.”

Getting Answers

You are now ready to go. If you just want to look at the answers, click on “Solve.” If you will want a printout of the entered data and the answers, click on “Format for Print.” If you want to start over with blank fields in the question boxes, click on “Clear Fields.”

Table A2-1. Input/Output Information for ASHRAE Standard 152.

House Information			
Building Floor Area :	1800 sq ft		
Location of house:	KansasCity,MO		
Duct Location Information and Thermal Energy Regain			
--LOCATION--	--SUPPLY--	--RETURN--	--REGAIN--
Attic:	0.00	0.00	0.10
Garage:	0.00	0.00	0.05
Unvented uninsulated crawlspace:	0.00	0.00	0.60
Unvented crawlspace, insulated walls and building floor:	0.00	0.00	0.30
Unvented crawlspace, insulated building floor:	0.00	0.00	0.16
Vented uninsulated crawlspace:	0.00	0.00	0.50
Vented crawlspace with insulated walls and building floor:	0.00	0.00	0.17
Vented crawlspace with insulated building floor:	1.00	1.00	0.12
Uninsulated basement:	0.00	0.00	0.50
Basement with insulated walls:	0.00	0.00	0.75
Basement with insulated ceiling:	0.00	0.00	0.30
Slab:	0.00	0.00	0.90
Exterior walls:	0.00	0.00	0.50
Duct Information			
Number of Return Registers:	2		
Supply Duct Surface Area:	486 sq ft		
Return Duct Surface Area:	180 sq ft		
Type of material:	Metal		

Supply Duct Insulation:	4.0 F ft ² /Btu-hr
Return Duct Insulation:	4.0 F ft ² /Btu-hr
Attic venting:	Well vented
Attic temperature reduction measures:	Non-existent

Heating Equipment Information

Type of heating system:	Gas
Heating equipment capacity:	70000 Btu/hr
Heating fan flow:	1000 cfm
Heating supply duct leakage:	200 cfm
Heating return duct leakage:	100 cfm

Cooling Equipment Information

Cooling equipment speed:	Single capacity		
	Normal	High	
Cooling equipment capacity:	30000 Btu/hr	0 Btu/hr	
Cooling fan flow:	1000 cfm	0 cfm	
Cooling supply duct leakage:	200 cfm	0 cfm	
Cooling return duct leakage:	100 cfm	0 cfm	
Cooling system control:	TXV control		
ACCAD design:	Was performed		

Distribution System Efficiency

Heating Seasonal	0.60
Heating Design	0.51
Cooling Seasonal	0.78
Cooling Design	0.51

Use your browsers back button to do another calculation.

INSTALLATION AND REPAIR OF DUCT SYSTEMS

Volume 6

**Better Duct Systems
for
Home Heating and Cooling**

Rev: November 15, 2000

INSTALLATION AND REPAIR OF DUCT SYSTEMS

This is the sixth in a series of guides intended to provide a working knowledge of residential heating and cooling duct systems, an understanding of the major issues concerning efficiency, comfort, health, and safety, and practical tips on installation and repair of duct systems. These guides are for use by contractors, system designers, advanced technicians, and other heating, ventilating, and air-conditioning (HVAC) professionals.

The choice of materials and techniques for installing ducts is limited only by what whoever is making the decision is willing to consider. Duct repair options are more constrained. You have to work with what is in front of you. This booklet takes up repair of ducts first, and then considers installation.

REPAIRING FAULTY DUCT SYSTEMS

The state of the art in duct repair is moving forward rapidly. Any duct retrofit business worthy of the name will require that its technicians receive hands-on training at a good duct-repair school. Periodic updating of technique is also highly recommended. Although reading this manual is not, by itself, sufficient to impart proper duct repair technique, it can serve as a useful introduction to the subject.

“Is it all right to use duct tape?” That’s one of the first questions that usually is asked in a duct repair class. The answer follows from one of the first rules that is usually expounded in such courses: “A duct repair should last as long as the ducts themselves.” That immediately rules out most kinds of duct tape as candidates for duct sealing. (There is an exception in fibrous-glass duct board.) A prohibition against duct tape certainly applies to the fabric-backed tapes with rubber-based adhesive that usually come to mind when one thinks of duct tape. These tapes have been found to fail rapidly when subjected to the conditions of temperature, humidity, and pressure normally encountered in ducts, as shown in Figure 1. Newer tapes specifically designed for duct repair are coming onto the market, and it is possible that some of these will stand the test of time. For any type of tape proposed for use in duct sealing, however, the burden of proof is very much on the manufacturer to demonstrate long-term effectiveness. With respect to duct tapes, the watchword has to be, “If in doubt, don’t use it.”

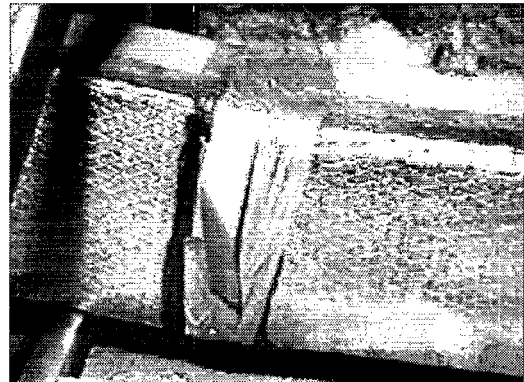

Figure 1 Common “duct tape” is not the answer to good duct repairs.

What, then, is recommended? This depends on the material from which the duct is constructed, but the best general answer is a special UL Listed (not just UL Classified) adhesive, called mastic (Figure 2), preferably one that is specially formulated for duct repair. The difference between UL Listed and Classified is that UL Classified tests mainly for problems relating to fire, whereas UL

Listed tests for many things, of which the most important for our purposes is co-adhesion (holding ability and elasticity). For small leaks, less than 1/4 inch wide, a bead of mastic alone will usually be sufficient to stop the leak. For larger gaps, first apply a layer of mastic at least 3" wide over the entire crack length, and then embed a layer of fiberglass mesh at least 2" wide in the mastic and then apply a final layer of mastic over the mesh. Proper technique in this application is best learned from an experienced practitioner, but aside from the fact that some leaks may be awkward to reach by a person with an average-size pair of arms and hands, the process is not difficult. Aside from the basic hand-sealing technique, practitioners should keep abreast of new technology of automatic duct sealing, such as the use of aerosol sealants blown into the duct with a computer-controlled adjustable-speed fan.

General Considerations Applying to All Kinds of Duct Systems

Coming onto a job site, a duct retrofitter first needs to resolve the question, "Does this duct system need fixing or not?" All of the following factors should be considered:

- Health and safety issues. These include induction of unwanted gases, vapors, and particulates, into the duct system; interference with the operation of combustion appliances; and biological growth caused by poor humidity control. See Volume 2 for further information.
- Thermal comfort problems. These include inadequate cooling capacity; poor control of humidity; too-low delivered air temperature with heat pumps; and individual rooms that are inadequately conditioned. They are also discussed in Volume 2.
- Low Distribution efficiency. For many customers, a good dollar payback will be a necessary selling point, but for those who are environmentally conscious the satisfaction of making one's heating and cooling system as "green" as possible may loom even larger than the economic benefits. Volume 5 discusses the diagnosis of duct leakage and the assessment of overall duct efficiency.

Joining flex-duct with metal fittings

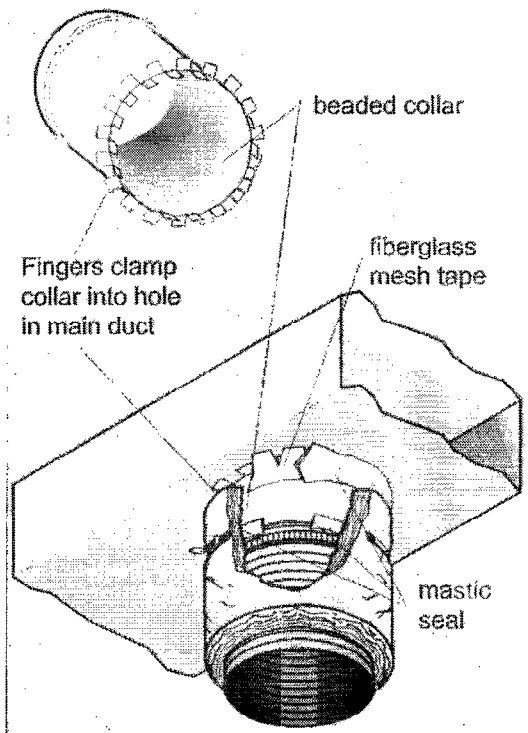

Figure 2 Illustration of fiberglass mesh tape used with mastic which works with most types of duct materials.

Illustration Credit: Consortium for Energy Efficiency

- “Double-dip” benefits of duct repair. In some cases, repairing the duct system may provide a double benefit. Fixing duct leakage can improve efficiency and eliminate health risks at the same time. In heat-pump systems, fixing the ducts may improve the heat pump’s efficiency as well as that of the duct system itself. If equipment needs replacing, fixing the ducts may enable the contractor to specify a smaller unit, saving the customer money that way in addition to the savings on energy. Volume 3 discusses these and other customer benefits from better duct systems.

Plan the Duct Repair Job

Whenever these considerations point to duct repair, a plan should be developed for the job. This need not be a lengthy affair, but it should include the following steps:

- 1) Sketch the duct system. Emphasis is on the word “sketch.” No detailed scale drawing or artistic talent is required, but it is very useful to have a good idea of where each duct section goes and what the connections are between the registers (visible in the living space) and the duct runouts (visible in the buffer space).
- 2) Evaluate the fundamental integrity of the duct system. Replace any portions of the system that are decrepit or for which replacement is the most cost-effective option. Note any disconnected ducts or other large holes in the system for later repair.
- 3) Seal the ducts. Those parts of the system that are in good condition structurally, but which leak, should be sealed, and disconnected ducts should be reconnected.
- 4) Insulate ducts. Any portions of the system, old or replacement, that need insulation can now receive it.
- 5) Correct zone pressure imbalance problems. After all of the above repairs have been completed, if any zone pressure imbalances remain, they should be corrected. The final part of this step will include a worst-case depressurization test for any zones containing combustion equipment. (See the Appendix to this volume.)

Evaluate Structural Integrity and Fitness for Repair

Once the duct system has been sketched, it is time to do a “broad-brush” general evaluation. Some practitioners will have made it a point, as part of the diagnostic procedure described in Volume 5, to inspect the duct system sufficiently thoroughly that it need not be inspected again. Others, however, will have done a more limited diagnostic inspection aimed only at detecting obvious problems, relying mainly on the duct blower to determine whether or not repairs are needed. In that case, a more complete visual going-over should be done before the repair process begins.

In certain cases it will be advisable to replace one or more duct sections. This will be the case when:

- The structural integrity of the duct section has been seriously compromised.
- Parts of the building have been used as ducts in such a manner as to make sealing excessively difficult or of questionable value.
- Replacement is less costly than repair.

The structural integrity of duct systems can be affected by long-term physical, chemical, or biological deterioration or by specific incidents of abuse. Such cases are not limited to any particular type of duct material. Examples would be rusted-out sheet metal, torn flex duct, or crushed duct board. In cases where almost the entire duct system has been allowed to deteriorate, the best approach may be to remove it completely and install a new, optimally designed system. In most cases, however, any severe deterioration will be limited to small portions of the system. In such cases, replacing the severely damaged sections should be done as a first step.

A second type of situation where replacement is a good idea would be where portions of the building have been used as ducts in a way that makes sealing excessively difficult. This is most common on return ducts. Chases or other internal building spaces are often pressed into service as return ducts on the theory that since the return air has not yet been conditioned, it is not important where it comes from or how it gets back to the central air handler. This philosophy often leads to a high rate of return leakage from the outside, which is the most common cause of the health, safety, and comfort problems discussed in Volume 2.

In some systems there is no return ductwork at all. (This is especially common in manufactured housing.) If the equipment is inside the conditioned space, this can be made to work if there is unimpeded flow of air from all the supply registers back to the air handler, and if the supply ducts are either very well sealed or in the conditioned space. However, if the equipment is outside the conditioned space (and this includes an unconditioned basement) and there is no return duct system, it will usually be advisable to install one.

The decision whether to repair or replace will often be strongly influenced by economics. Flex duct, for example, is relatively quick and cheap to install, so any torn section should be replaced. Replacement of sheet metal and duct board is more involved, and so repair options are more often selected.

In the course of inspecting the duct system for structural integrity, it is important to look for disconnected ducts. These may not be obvious, especially if the system is insulated with duct wrap. A joint may look sound, but may actually have a sizable air gap beneath the insulation. If a runout moves sideways under a gentle push near its junction with the main trunk, it's a good clue that all is not well beneath the surface. A black sooty zone on the insulation at a junction is another clue that a large hole lies hidden there. If any duct junction is suspected of being wholly or partially disconnected or of having a large hole for some other reason, the insulation can be pulled back at the site for a visual inspection. The location of any disconnects or large holes should be noted on the duct sketch for later repair.

Finally, the boots and registers should be inspected for significant gaps between the register edge and the opening into the room. This can be a significant source of air leakage, not only into the duct system when the fan is on, but from the outside to the room when the fan is off! Note the existence of such gaps for later repair using mastic and fiberglass mesh fabric.

Duct Sealing

The duct sealing procedure can be divided into two portions:

- Repairing large leaks found during the general inspection.
- Finding and repairing other leaks.

Disconnected ducts must be reconnected. Sometimes the physical reconnection will be a relatively simple task, essentially the same as if the section had been correctly installed in the first place. Other times, the disconnect will be due to failure of some component, in which case this will have to be replaced. In either case, the reconnection should be considered as just the first part of the job, having converted a large leak (the disconnect) into a smaller one (the total leakage around the remaining cracks and spaces in the joint, of which there will usually be some).

The second step is to repair these cracks, as well as any other previously-found holes that are not disconnects. The proper procedure here, and for any separation that is greater than 1/4 inch in width, is first to apply a layer of mastic at least 3" wide over the entire crack length, and then embed a layer of fiberglass mesh at least 2" wide in the mastic and then apply a final layer of mastic over the mesh. For extremely large holes, as are often found where building spaces are used as ducts, it may be necessary to "box in" an opening (such as a wall cavity leading to a register) before sealing with mastic.

If possible, it is usually preferable to seal supply ducts from the inside and return ducts from the outside, so that the pressure difference works to keep the seal in place rather than to force it out. An exception is duct sections using building spaces, where sealing from the inside, where possible, is usually better regardless of whether it is a supply or return, because it is easier to make sure you have eliminated all leakage paths. This especially important with platform returns and other large ducts built up from materials such as studs and wallboard. Often, however, it will be necessary to work from "wrong" side, and that is perfectly acceptable as long as the seal is soundly made.

Once these larger holes have been found and sealed, the decision must be made on what to do about smaller leaks. There are three possibilities:

- Ignore them.
- Seal by hand.
- Use aerosol sealing.

In some cases the leakage may be all or nearly all in leaks that were found on inspection. If this is thought to be the case, the duct blower test can be repeated at this point (wait for the mastic to dry, though!), and if the remaining leaks are small enough that further repair is not warranted (for example, if the system now meets the criterion set by an energy-efficiency program in which the duct-repair team is participating), then it would be acceptable to stop work at this point.

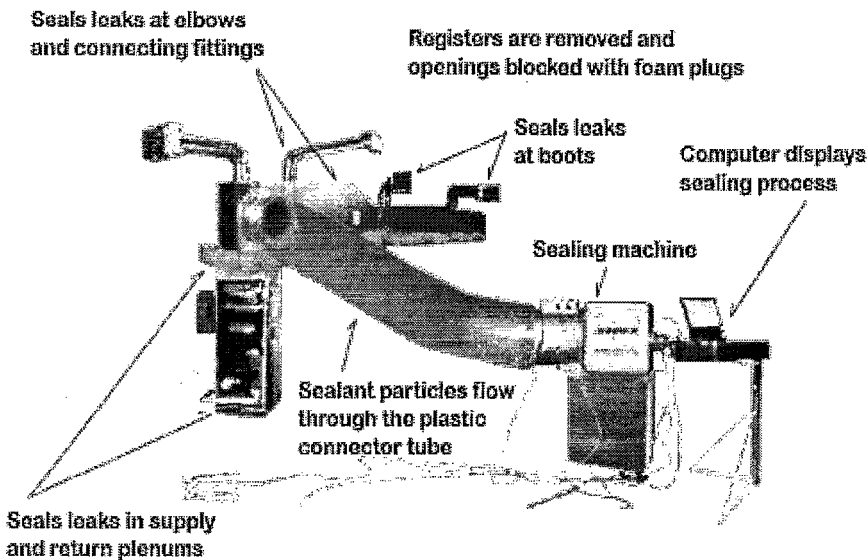

Figure 3 Aerosol sealing requires a trained specialist using a controlled process to inject aerosol particles into the duct system.

Unfortunately, further effort will usually be necessary. At this point it is necessary to decide between hand sealing and aerosol sealing (Figure 3). The relative merits of these approaches will depend in part on the duct material one is working with--sheet metal, flex duct, or duct board.

Sealing by hand is the traditional method. As discussed above, mastic (either with or without fiberglass fabric depending on the size of the leak) is the material of choice.

Of course, in order to seal leaks by hand one has to find them. Here there are two basic methods:

- Seal anything that might be a leak whether or not you know that it is.
- Use some helpful technique to find the actual leakage sites.

The first method is not as ridiculous as it sounds. Duct-repair practitioners may find, in the course of attending to a large number of houses in a particular area, that some generic type of possible leakage site usually does need sealing. An example could be transverse joints in sheet-metal ducts. It may be a time-saver in such cases just to go ahead and seal all of these joints without worrying about whether they leak. In other words, if it's a probable leak site, just go ahead and seal it with mastic.

However, it is also handy to have a couple of tools handy. This is especially important because most duct systems have parts that are not easy to look at. The duct may already be insulated with duct wrap. Or there may be a big hole in the part of a runout or boot that is hidden just an inch or two from a wall or ceiling, which you would not find without some help.

Theatrical smoke is one such handy tool. Small hand-held smoke generators can be purchased at some hardware stores or from specialty supply houses. Theatrical smoke can be used during the duct blower test. Introduce the smoke at the inlet side of the duct-blower fan and watch to see where it comes out. Another technique can be to depressurize the duct with the duct blower and go around the system with the smoke generator, squirting smoke around areas of suspected leakage and seeing whether it is sucked into the duct. A third approach is to run the system normally and see whether smoke is drawn into the return side or blown away from the supply ducts when the smoke generator is held near suspected leak sites.

Make sure that the type of smoke used is of acceptably low toxicity and that the house is well ventilated during and after the test. (This type of smoke can also be used in the final zone pressurization test described in the appendix.)

Another useful tool in finding duct leaks is the pressure pan. This device looks like an ordinary baking pan. A nipple is fitted onto the surface of the pan, such that a plastic tube can be run from the pan to a digital pressure gauge, allowing the pressure on the inside of the pan to be read off. The use of the pressure pan is as follows. With a blower door, pressurize the house to 25 pascals. Then place the pressure pan over each register in turn and read the pressure. If there is relatively little duct leakage in the runout leading to the register being tested, the reading will be a low number, 2 pascals or less. The other extreme would be if the duct leading to this register is disconnected at the boot. In this case, when the pan is pressed against the register, it will be “seeing” the outside, and the pressure difference will be close to 25 pascals.



Figure 4 Pressure pan, pressure connection on right hand side.



Figure 5 Pressure pan used to determine duct leakage in individual duct branches

By measuring the pressures at each register with the pressure pan, one can get a good idea of where the worst leaks are and make a special effort to find them. A limitation of this approach is that it may not locate leaks that are far from any register (i.e., close to the supply or return plenum), but

even here there may be a clue if, for example, one notices a systematic trend of high readings in the supply registers a short distance from the plenum and lower readings in the supply registers farthest from the plenum.

With hand sealing, the technique is to cover with mastic any suspected or confirmed leaks, let it dry, and then retest the system with the duct blower. A reasonable goal for a wholehearted effort is to bring the duct system well within any compliance criterion with which the retrofit team is working. Another good rule of thumb is to try to seal at least two-thirds of the original leakage area.

Aerosol sealing (see Figure 3) is a relatively new approach in which all openings to the duct but one (usually the largest) are temporarily blocked off, and a special blower is attached to the remaining opening. This device is then used to spray in small droplets of a rubberlike material which finds its way to small holes and cracks in the ducts and seals them, in much the same way as “instant spare” products do for emergency road repair of flat tires. Field tests of the technique indicate that it is very effective when there are numerous small leaks. It is less effective on larger leaks, so the preliminary search for such leaks still needs to be carried out, and these larger leaks should be dealt with by an appropriate hand-repair technique. In most cases, the number of such larger leaks will be small enough that the total time involved in aerosol sealing will be less than that for hand sealing, particularly for high target levels of sealing effectiveness.

Insulating Duct Systems

Some types of duct material come already insulated. These are duct board and flexible ducts, which are generally available with effective R-values ranging from 4 to 8. Sheet-metal ducts may be found in an insulated or uninsulated condition. In either case, additional insulation can be added in the form of duct wrap. For ducts installed on the floor of an attic, an alternative insulation method is to “fence off” the ducts with vertical barriers to the left and to the right of each duct run and fill the space between the barriers (which includes the duct run) with loose-fill insulating material.

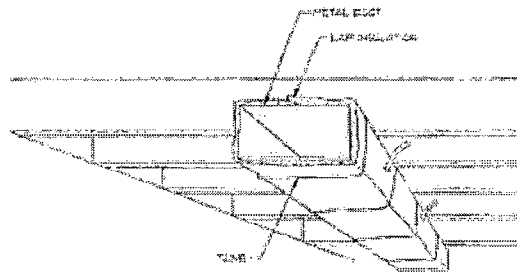

Figure 6 Additional duct insulation can reduce heat loss by increasing effective R-value.

Correcting Zone Pressure Imbalances

Pressure imbalances giving rise to depressurization of equipment rooms (including rooms containing fireplaces and other room heating devices) must be corrected, as explained in Volume 2. The equipment room is the smallest space, containing the combustion appliances, that can be separated from the rest of the house by closing doors. This is very commonly the basement, though it can be a room within the basement, a utility room, a crawl space, or a garage. The recommended maximum pressure difference is generally considered to be 3 pascals, although somewhat larger pressure differences may be acceptable if all combustion appliances use sealed combustion. Equipment-

room depressurization problems existing before the duct repair will usually be rectified by sealing return ducts in the equipment room. Correcting inter-zone pressure differences (see below) can also help. The final option, if all else fails, is to install a transfer duct between the equipment room and the outside.

Pressure imbalances between two zones, neither of which contains combustion equipment, should also be rectified if they cause comfort problems that are noticeable to the occupants or if they are found to exceed 3 pascals. If possible, smaller imbalances in the 2 to 3 pascal range should also be addressed. Large pressure differences will usually require the installation of a grille or transfer duct between the two zones. Smaller pressure differences may be corrected by undercutting a door between the zones.

Testing for equipment-room depressurization and inter-zone pressure differences is discussed further in the Appendix to this volume.

Special Tips for Repair of Specific Kinds of Ducts

The following sections are keyed to the major duct types: sheet metal, duct board, flex duct, and built-in ducts.

Sheet Metal Ducts. The above discussion is most specific for sheet metal ducts, and so few additional comments are necessary.

A major issue with these systems is finding enough of the leaks to make the job worthwhile. This can be especially problematic if a significant portion of the duct system is located in hard-to-reach areas or if it is already covered with insulation.

When sealing sheet-metal ductwork, the places to emphasize are:

- Joints between trunks and runouts. These are usually fairly easy to get at because insulation, if present, usually has to be joined here also.
- Leaks around register boots, both at the interface between the boot and the floor or wall and at the joint between the boot and the runout. These leakage zones are best reached by removing the register grille and working from the inside.
- Transverse seams in trunks and runouts. These may be more difficult to reach if covered by insulation. Do the best you can here and hope that in this system transverse seam leaks are minor. Fortunately this is often the case.

Flexible Ducts. Repair of flexible ducts generally involves the following activities:

- Removing excessive length of duct.

- Correcting drooping sections.
- Replacing damaged/torn lengths of flex duct
- Securing and sealing end clamps.

In poor installations of flex duct, installers will sometimes omit the step of cutting the sections to the proper length. Instead, they will attach one end of a standard-length section to the plenum and the other end to the register, and then heave the excess length into an unused space. The serpentine flow path inhibits air flow and may cause poor allocation of the cooling or heating between rooms. Such installations should be upgraded by disconnecting one end of each affected section, cutting out the excess length, and securely reattaching it.

A related fault is using an insufficient number of supports to the flex duct, which results in drooping sections. Generally, supports should not be more than 5 ft apart, and sag should not be more than 1/2 in. per running foot of duct. In both of the above types of improper installations, pressure drops are higher and air flow is lower than would be the case if installation had followed the manufacturer's guidelines. Even if the improperly installed sections don't leak themselves, the increased pressure drops will induce incremental leakages elsewhere in the system. If the droops are not too pronounced, extra supports can be added to the system. In extreme cases, the section may need to be replaced.

Although flex duct (unless torn) does not leak between one end and the other, the end connections can leak excessively. These can be repaired by loosening the end clamp, securing the inner liner of the flex duct to the boot or trunk collar using mastic and fiberglass fabric (see Figure 2), and then reattaching the end clamp and tightening it over the entire end of the flex duct.

The situation with torn duct has been touched on earlier. Replace the affected section(s).

Duct Board. Repair of fibrous glass duct board systems should generally follow the same procedures as installation of a new system, but with the usual simplification that the system design is already laid out for you, and all that needs to be done is to reattach/reseal the seams and joints. For any sections where the duct board itself is severely damaged, a new section should be fabricated to replace it. Following this step, any closures that no longer represent a firm, tight seal should be carefully removed, and new closures installed to replace those that were removed or were missing altogether.

Closures for duct board systems include pressure-sensitive aluminum foil tapes, heat-sensitive aluminum foil tapes, and mastic and glass fabric tape systems. These closure systems are governed by Underwriters Laboratory standards UL 181 and UL 181A, and only those systems complying with these standards should be used. These tapes as applied to duct board are the major exception to the advice against using duct tape, discussed at the beginning of this chapter.

Duct board systems usually are provided with staple flaps, which are extra widths of foil backing that can be overlapped onto the next section of board and stapled down to form a secure equipment joint. If this has become torn, shredded, or otherwise useless, it can be removed and replaced with cross

tabs placed across the joint in question to provide equipment stability. The same type of tape used in seam closures is generally used for the cross tabs, which are recommended to be at least 8 inches in length and installed every 12 inches along the seam.

Once the joint has been secured mechanically, either by restapling the staple flap or installing cross tabs, it should be air sealed with a length of closure tape installed longitudinally along the seam and overlapping both sides equally. The critical factor in seal longevity is surface preparation. It should be assumed that any ductwork that has been in a building long enough to need repair is for that reason far from clean even if visible dirt is not present. Accumulations of thin surface coating of oils or other slick contaminants may well escape an “eyeball assessment.” All approved tapes will come with cleaning recommendations for that specific variety of tape, and these should be followed religiously.

Parts of the Building Used as Ducts. Perhaps the most problematic aspect of duct sealing is where parts of the building are incorporated into the air-moving system. It is very likely that there will be pathways for air to escape the system that are not at all obvious. This is especially true in situations where you can’t see all of the surfaces of the “built-in” duct, and unfortunately this will usually be the case. A reasonable maxim is that if you can’t see that it is sealed, it probably isn’t.

Several types of situations should be discussed. Sometimes a very large chase is used as a return duct, and this may have such extensive pathways for air flow from the attic, inter-floor spaces, basement, and other spaces connected to the outside that any thought of sealing them all is out of the question. In such a case the best solution may be to fabricate and install a real return duct system within this large chase, connecting the return registers to the return plenum at the equipment.

The next case down, in order of severity, would be where it is possible to identify all or nearly all of the openings where communication to the outside is possible. Where a vertical stud space is used as a duct, for example, a good solution may be to install a barrier of wood or sheet rock just beyond the register and then seal the cracks around its edges with mastic. In general, the idea is to close off all “avenues into the unknown” or pathways into large interstitial spaces of the building with unknown connections to the outside.

Finally, it often happens that most of a duct system uses real ducts but has a few panned joists in the basement. A good strategy here may be to seal the accessible parts of the system and then retest for leakage as discussed in Chapter 8. If the leakage is still unacceptably high, it may be necessary to open up the panned joists by removing the rectangular pieces of sheet metal joining the bottom edges of the joists, in order to visually assess and fix the remaining leakage problem.

INSTALLING NEW DUCT SYSTEMS

It might seem that things are in better shape with a new duct system than with an existing one. After all, in a new building there is still freedom to design and build the system “from the ground up.”

However, even in new buildings contractors face a major problem: they don't make all the decisions.

General Considerations

In the best of all possible worlds, the architect, builder, and HVAC contractor would work together to achieve a duct system that would deliver heating and cooling safely, comfortably, and efficiently. Working as a design team, they would follow these guidelines in achieving a well-designed building system that would include an efficient air moving system.

In this, as in most other areas of human endeavor, the real world often falls far short of the ideal. The HVAC contractor is usually brought onto the job only after the house is built. The contractor is also limited by the resources of time, materials, and effort he can apply to the job, which he most likely got by being the low bidder.

Lacking the incentives and the resources to install an excellent duct system, a contractor facing the conditions described in the previous paragraph will be doing well to apply as many of the suggestions in this and other manuals as he can, and should be applauded for any such efforts. The rest of this chapter, however, presupposes that these conditions can change.

Such change might be brought about fairly simply. The architect or the builder--or the home buyer if the house is being built to order rather than "on spec"--could add one simple sentence to the specifications:

"The duct system shall have a seasonal distribution efficiency of at least 90% in both the heating and cooling modes, and this shall be confirmed through testing using ASHRAE Standard 152."

This changes the game. If such a specification were the norm, or at least became common, contractors bidding on jobs would have to take the requirement into account. To keep the bids from being raised too much by this requirement, designers of homes would need to consider the duct system during the design, both in terms of optimizing the heating and cooling loads and of facilitating good choices for duct location.

To help bring about this "better world to come," the following checklist is presented.

1. First do no harm. This dictum from the medical profession applies here in the sense of not making serious mistakes. Probably the most important of these is not to use the building as the duct system. One might of course ask "Why not?" if the parts of the building one proposes to use are in the conditioned space. But as we've seen, what seems to be in the conditioned space often isn't, or more precisely, what seems to be in the conditioned space often connects to the outside in ways that

can't be anticipated. As with almost any rule, there may be exceptions, but these would be limited to design concepts that have been tested in the field by competent personnel and found to have acceptably low outside leakage. Even here, though, one builder's success should not be taken for granted: any duct system that could possibly have outside leakage should be tested to confirm its soundness.

2. Minimize heating and cooling loads. This, of course, is for the architect and builder rather than the HVAC contractor, but still it needs to be kept in mind by all parties. Downsize the loads and you can downsize the equipment and ducts, reducing HVAC design and installation problems to a minimum.

3. Consider placing the ductwork in the conditioned space. Again, this is a design issue that must at least be acquiesced in by the architect and builder, but which will be seen more and more often as time goes on. If this isn't possible, the basement is the next best choice if the house has one. Attics are generally the poorest choices, but are very common in hot, humid climates where most houses are slab-on-grade and the attic is the only available space that is "out of sight." It's this type of situation where making the effort to get the ducts into the living space pays the biggest dividends for the home buyer.

4. Minimize the surface area of any ducts that are not in the conditioned space. Granted, putting the ducts in the living space is sometimes not an option. Even so, it is still not necessary to saddle the homeowner with an excessively bulky system. When the exterior walls and windows are designed to have high thermal resistance values, the need to place registers beneath windows fades, and a much more compact duct system with registers on interior walls becomes feasible.

So far, the discussion has been mostly about design issues. Duct design is discussed in Volume 4, with options for ducts inside and outside the conditioned space.

5. Make sure that any ducts that are not in the conditioned space are sealed and insulated. The one exception is that in an unconditioned basement it may not be necessary to insulate return ducts (although they should be sealed).

6. Test the completed duct system for leakage. If, despite every attempt to follow good practice the leakage rates are found to be excessive, treat the system as you would a retrofit and set things right.

Installing Efficient Sheet-Metal Ducts

Sheet metal has the advantage of durability, and it is the most commonly used duct material in many parts of the United States. Perhaps its greatest drawback, at least from an efficiency standpoint, is that it is quite possible for a good-looking, professionally installed system to leak badly. It's also possible for a duct system that is "designed on the fly" to end up much more convoluted than it needs to be. The following points should therefore be kept in mind when working with sheet metal:

- Design the duct system according to ACCA Manual D.
- Minimize the surface area of ducts that are not in the conditioned space. Consider two or three approaches to ducting the house, and run Manual D calculations for each. You may find that some systems can provide the same level of comfort as others and yet be more compact. Chances are that after a while you'll develop some intuition about what usually is the best approach to duct layout for the house types in your area, and you'll no longer have to do more than one generic layout. Of course, the simplest method (at least conceptually) to minimize the amount of ductwork outside the conditioned space is to put all of it inside!
- Make sure that duct sections are firmly connected with screws and then (if outside the conditioned space) sealed with mastic.
- Take the trouble to insulate all ducts outside the conditioned space. (A possible exception to this requirement would be return ducts in an unconditioned basement.) Consider using R-8 insulation on supply ducts.
- Resist the temptation to use panned joists and other applications of the building as ductwork.

Installing Efficient Fibrous Glass Ducts

Fibrous glass duct board has the advantage that it comes already insulated. Some suggestions for working with this material are:

- As with sheet metal, design the duct system according to ACCA Manual D and minimize surface area outside the conditioned space.
- In locating duct board systems within a house, consider whether people (whether occupants or other trades) are likely to damage the ducts while attempting to climb over them or by storing household goods on top of them. Place the ducts to minimize this possibility.
- Fabricate the duct sections carefully, so that they will fit together snugly.
- Clean surfaces thoroughly before applying closures. Although a special type of tape is generally used to attach the pieces of this ductwork and seal it, duct board systems will leak, perhaps immediately but certainly in time, if the tape is not meticulously applied.
- Support the duct sections properly. Fibrous glass duct board is not a structural or load-bearing material!

Installing Efficient Flexible Ducts

The greatest advantage of flexible ducting, as far as efficiency is concerned, is that they don't leak between ends unless torn. They are easy to work with, and this can be their greatest drawback when unqualified installers are used. Suggestions for working with flexible ducts would include:

- As with sheet metal or duct board, design the duct system according to ACCA Manual D and minimize surface area outside the conditioned space.
- Support the sections properly. Leaving too much space between supports will result in excess sag, which increases pressure drops and cuts air flow. That can lead to greater leakage at the ends of the flexible duct runs or elsewhere in the system.
- Cut the duct sections to the proper length before installing. Serpentine bends in excess length has the same effect in the horizontal dimension that poor supporting practice does in the vertical.
- Make sure all end connections are tight and sealed with mastic, to ensure long-lived, leak-free joints.

Installing Efficient Ducts Using Building Spaces

The most appropriate comment here is, "Don't try." However, if it is absolutely necessary to pan joists, then do it as sparingly as possible and, where it is done, smear the inner sides and top of the joist space with mastic before applying the sheet-metal cover. After installing the sheet-metal strip, seal the edges with mastic as well. And don't forget the ends. Don't assume that the plate or sill at the end of the joists will form a seal. Install and mastic seal special ends just for the duct section.

APPENDIX. Testing for zone pressurization.

Because pressure imbalances can have serious health and safety implications in some systems, it is imperative that technicians learn proper pressure-testing techniques in a recognized hands-on training session. This appendix summarizes one procedure for this testing to give an overview of what is involved. It is intended to be used as preliminary reading, prior to taking such a course, and as a reference for later use by trained personnel. Reading this appendix is not, by itself, sufficient to certify a technician in zone pressure testing.

There are two distinct goals in zone pressurization testing. The first, and most important, is testing for worst-case depressurization of a room or zone containing combustion appliances. As a rule, such an area of the building should not be allowed to depressurize more than 3 pascals relative to the outside.

The second goal is to look for pressure differences between zones that can be isolated, one from the other, by closed doors. Pressure differences of more than 2 to 3 pascals should be relieved by providing an adequate air-flow path between the zones.

Equipment-Room Depressurization Test

In order to describe the depressurization test procedure in general terms, the space containing the combustion appliances which is being tested for depressurization, will be referred to as the equipment room. The equipment room is the smallest space, containing the combustion appliances, that can be separated from the rest of the house by closing doors. (This does not mean entirely closed off, however. National Fire Protection Association [NFPA] Standards 31 and 54 [for oil and gas, respectively] specify combustion air openings that must be provided in building spaces that contain heating appliances.) As noted above, this is very commonly the entire basement, but it may be a room within the basement, a utility room, a crawl space, or a garage.

Depressurization testing would be made easier if it weren't for the fact that the air handler fan in the HVAC system isn't the only thing that moves air in a typical house. There are usually also several exhaust fans, in bathrooms, over kitchen ranges, and in clothes dryers. These can work with the HVAC system to make depressurization a more serious problem than it otherwise would be. It is therefore necessary to find the worst case--that combination of fan operations and interior door positions that produces the greatest negative pressure in the equipment room.

The following test is suggested as a compromise between an inadequate test, or no test at all, on the one hand, and an exhaustive research project, on the other. It is simple to do, involving merely the successive opening and closing of interior doors and noting whether a puff of smoke goes under the door or not.

Equipment Room Depressurization Test Protocol

Step 1: Preliminaries

- Run a plastic tube to the equipment room and attach the other end to the input port of a digital manometer.
- Run another plastic tube to the attic (if vented) or to the outside, and attach its other end to the reference port of the manometer.
- Close all doors and windows between the living space and the outside.
- Close all doors and windows (if any) between the equipment room and the outside.
- Open all interior doors, including any between the living space and the equipment room.
- Make sure all exhaust fans and the system fan are off initially.

Step 2. Test with exhaust fans on. Turn on all exhaust fans in the living space and in the equipment room. Leave the HVAC system fan off.

- Do the smoke test, described in italics below, for each case where there is a room (such as a bedroom) that can be isolated from the equipment room by closing a door:¹
While you are standing in the main part of the living space, close the door to the room that can be isolated. Squirt a puff of smoke at the bottom of the door. If the smoke is drawn under the door into the room behind it, open this door. If the smoke is blown away from the door, that is, back towards you, leave the door closed.
- At the end of this process, record the pressure difference between the equipment room and the attic or outside (referred to subsequently as the ΔP).
- Now close the door between the equipment room and the living space and again record the ΔP .
- Finally, open all interior doors to prepare for the next step.

Step 3. Test with all fans on. Leave the exhaust fans on and turn on the HVAC system fan. Repeat Step 2. This will involve two more pressure-difference measurements.

Step 4. Test with system fan on. Leave the HVAC system fan on and turn the exhaust fan(s) off. Repeat Step 2. There will be two additional pressure-difference measurements, for a total of six in all.

Step 5. Find the most negative of the six pressure differences. This is the worst-case depressurization. If none of these ΔP 's is negative, the equipment room is under positive pressure and there is no depressurization.

¹If in a complex situation there is doubt which zone is “isolated” and which is the “main part,” use the following rule: the main part of the living space is the part that remains in communication with the equipment room through open doorways, whereas the isolated part is the part that is separated from the equipment room when the door or doors in question is (are) closed.

Data Sheet for Equipment-Room Depressurization Test

Step	Exhaust Fan(s)	System Fan	Interior Doors	Door(s) between Equipment Room and Living Space	ΔP , Equipment Room with Respect to Outside, Pa
1	Preliminary Setup		Open	Open	N/A
2A	On	Off	List Closed Doors:	Open	
2B	On	Off	Same as 2A	Closed	
3A	On	On	List Closed Doors:	Open	
3B	On	On	Same as 3A	Closed	
4A	Off	On	List Closed Doors:	Open	
4B	Off	On	Same as 4A	Closed	
5	Record the minimum from Steps 2A through 4B ⇒				

Note: Under “List Closed Doors,” say which doors are closed after the smoke tests. List by room or use some other naming or numbering system.

Inter-Zone Pressure Difference Test

Testing for inter-zone pressure differences is comparatively easy. Attach a plastic tube to the input port of a digital manometer. Run the free end of the tube through the doorway between the zones where a significant pressure difference may exist. Make sure all other operable openings between these zones are closed. With the system fan on, gradually close the door over the plastic tube, taking care not to pinch it, and note the effect of the door closure on the pressure reading.

If a pressure difference greater than the maximum allowable value (usually 2 or 3 pascals) is noted, then gradually open the door until the pressure difference drops enough that it is within the acceptable range. The open area between the edge of the door and the jamb will give a good indication of how much area must be introduced in a grille, transfer duct, or door undercut in order to relieve the pressure.

Repeat the test for all zones that can be isolated by closing interior doors.